

## SB04 Solar LED Billboard UpLight

### LED Solar Flood/Billboard Sign Light

#### OVERVIEW

<b>Wattage (W)</b>	15W, 25W, 30W
<b>Lumen Package (lm)</b>	3000 to 6000 lm
<b>Color Temperature (CCT)</b>	4000K (3000K, 6000K optional)
<b>Efficacy (lm/W)</b>	200 lm/W



#### DETAILS

This solar-powered uplight delivers powerful illumination for large-scale signage and billboard installations. With 6,000 lumens of neutral 4000K white light output, a high-efficiency bifacial solar panel, and long-lasting lithium battery, this light is optimized for reliable, off-grid performance. Intelligent dimming and rugged construction make it a dependable solution for exposed outdoor environments – especially ones requiring wide, even light distribution.

#### KEY FEATURES

- **200 lm/W:** Exceptional energy efficiency
- **Quick Charge:** 6–7 hours via solar
- **Auto Dimming for Extended Use:** Up to 2 nights
- **Durable Housing:** IP65 & IK08 rated
- **Billboard Ready:** Type III wide beam spread
- **Extension Wire:** 19.6ft (6m) extension wire

#### APPLICATIONS

- Highway Billboards
- Monument Signs
- Park & Campus Directories
- Entry Features
- Exterior Wall-Mounted Displays
- Temporary Construction Sites
- Solar-Only/Hard-to-Wire Installs

#### QUICK SHIP ORDERING GUIDE

 Example: **SB04-30-40**

SKU Root	Wattage / Lumens	CCT
SB04-	30 - 30W, 6,000 lumens	40 - 4000K

# SB04 Solar LED Billboard UpLight

## LED Solar Flood/Billboard Sign Light

### SPECIFICATIONS

<b>Wattage &amp; Lumens</b>	15W, 3,000 lumens 25W, 5,000 lumens 30W, 6,000 lumens
<b>Efficacy</b>	200 lm/W
<b>CCT</b>	4000K (3000K, 6000K optional)
<b>CRI (Ra)</b>	70
<b>Controls</b>	Timer Dimming
<b>Battery Type</b>	Lithium Ion
<b>Battery Capacity</b>	15W: 12V/18AH 25W: 12V/25AH 30W: 12V/30AH
<b>Solar Panel Type</b>	Mono-Crystalline Bifacial Solar Panel
<b>Solar Panel Wattage</b>	18V/50W
<b>Charging Time</b>	6-7 hours*
<b>Operating Time</b>	Time Control: 1-2 Days*
<b>Solar Charge Controller</b>	MPPT
<b>Working Mode</b>	First Hour 100% Brightness 2nd Hour 80% 3rd-4th Hour 60% 5th Hour Till Dawn 20%
<b>LED Type</b>	LED 5050
<b>Average Lifetime</b>	L70: 50,000 hours
<b>Beam Angle</b>	Type III
<b>Mounting</b>	Bracket Mount
<b>Operating Temperature</b>	-20°C to 60°C (-4°F to 140°F) Battery Charging Temperature: 0°C to 45°C (32°F to 113°F)
<b>Material</b>	Aluminum Housing, Polycarbonate Optical Lens, Li-ion Battery, Mono-crystalline Solar Panel
<b>Fixture Color</b>	Black
<b>IP Rating</b>	IP65
<b>IK Rating</b>	IK08
<b>Warranty</b>	3 Years

\*Performance based on ideal conditions - solar lights are heavily affected by sunlight levels temperatures, snow, dirt, and other conditions.

## SB04 Solar LED Billboard UpLight

LED Solar Flood/Billboard Sign Light

### COMPLETE ORDERING GUIDE

Example: **SB04-15-40**

SKU Root	Wattage / Lumens	CCT
SB04-	15 - 15W, 3,000 lumens	30 - 3000K
	25 - 25W, 5,000 lumens	40 - 4000K
	30 - 30W, 6,000 lumens	60 - 6000K

\* Items in **GREEN** are Quick Ship. Items in **BLACK** are by special order.

### PRODUCT DIMENSIONS

MODEL	30W
Product Dimension	29.32" x 17.85" x 19.46" (744.85 x 453.50 x 494.29 mm)

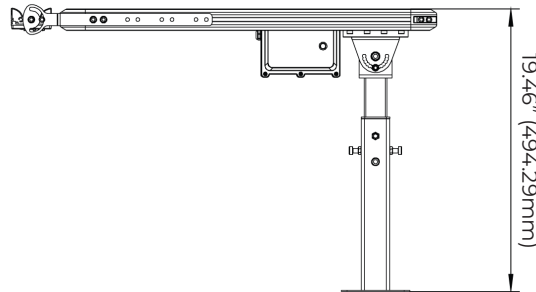
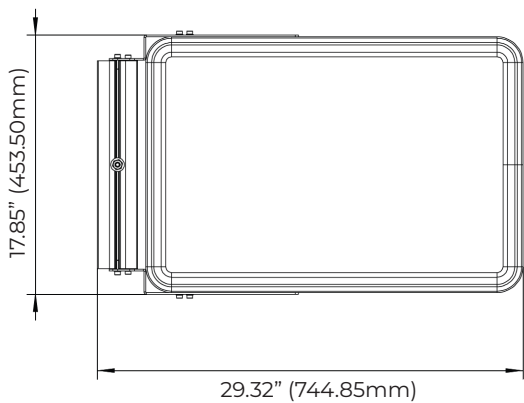

### PERFORMANCE

Model	Wattage	4000K	
		Lumens	Efficacy
SB04-15-40	15	3000	200
SB04-25-40	25	5000	200
SB04-30-40	30	6000	200

## SB04 Solar LED Billboard UpLight

LED Solar Flood/Billboard Sign Light

### PHOTOMETRICS

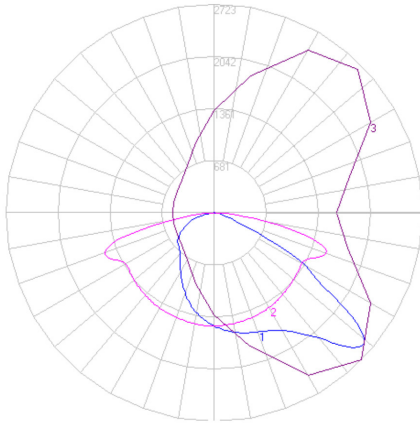

Type III

### MOUNTING



Bracket Mount



Ground Spike



Split Mount

### ACCESSORIES

SKU	Description	Image
SB04-GNDSPK	Garden Stake (Ground Spike) 20" x 4.72" x 4.72" - 5.5 lbs	
SB04-SPLITKIT	Split Kit (Remote Install) U-Bracket, Ground Spike, 19.6 ft (6m) Wire	