



## PRODUCT MANUAL

**BLINK SERIES 7 – ISO (MODEL 780, 748)**

**BLINK SERIES 8 – ISO (MODEL 880)**

Version 2.1



**MODEL 780, 748**

**MODEL 880**

---

© 2024 by Blink Charging Co. Its Affiliates and Subsidiaries (“Blink”)

No part of the contents of this document may be reproduced or transmitted in any form or by any means without the express written permission of *Blink*. The contents of this document have been verified by the manufacturer to be consistent with the described components; however, inconsistencies sometimes occur. Such inconsistencies should be brought to the attention of a *Blink* representative. Changes to this manual may be made at any time without notice.

### **Disclaimer of Consequential Damages**

*Blink* is not responsible for the use or application by any person of the materials in this manual. *Blink* is not responsible for damages, either direct or consequential, arising out of or relating to the use or application of these materials.

Certain sections of this manual are meant as a guide for professional electricians. The manual contains general guidelines and may not provide instructions for your specific situation. Do not attempt installation if you lack the knowledge and understanding required for the installation, otherwise personal injury and/or death as well as property damage or loss could occur.

Electricity is dangerous and can cause personal injury or death as well as other property loss or damage if not used or constructed properly. If you have any doubts whatsoever about performing the installation of the equipment, please do the smart thing and hire a licensed electrician to perform the work for you.

Never work with live voltage. Always disconnect the power source before working with electrical circuits.

When performing the installation, please read and follow this manual. Additionally, always follow your local electrical code and requirements which are specific to local areas.

### **Notice**

*Changes or modifications not expressly approved by the party responsible for compliance could void the user’s authority to operate the equipment.*

---

## Contents

<b>1. SAFETY AND COMPLIANCE.....</b>	<b>6</b>
1.1. GENERAL .....	8
1.2. STATEMENTS.....	8
<b>2. SYSTEM OVERVIEW .....</b>	<b>9</b>
2.1. PRODUCT SPECIFICATIONS.....	9
2.2. PRODUCT DIMENSIONS .....	10
2.2.1. SERIES 7 – ISO CHARGER WITH PEDESTAL DIMENSIONS: .....	10
2.2.2. SERIES 8 – ISO CHARGER WITH PEDESTAL DIMENSIONS: .....	11
2.2.3. SERIES 7 – ISO CHARGER WITH WALL MOUNT DIMENSIONS: .....	11
2.2.4. SERIES 8 – ISO CHARGER WITH WALL MOUNT DIMENSIONS: .....	12
2.2.5. SERIES 7 – ISO CHARGER WITH PEDESTAL AND CABLE MANAGEMENT SYSTEM:.....	12
2.2.6. SERIES 8 – ISO CHARGER WITH PEDESTAL AND CABLE MANAGEMENT SYSTEM:.....	13
2.2.7. SERIES 7 – ISO CHARGER WITH WALL MOUNT AND CABLE MANAGEMENT SYSTEM:.....	15
2.2.8. SERIES 8 – ISO CHARGER WITH WALL MOUNT AND CABLE MANAGEMENT SYSTEM:.....	16
<b>3. PLANNING AND DESIGN.....</b>	<b>17</b>
3.1. ELECTRICAL REQUIREMENTS.....	17
3.2. STATION CONNECTION DIAGRAMS .....	20
3.3. COMMUNICATION REQUIREMENTS.....	21
3.4. NETWORK PLATFORM REQUIREMENTS.....	22
3.5. TOOLS REQUIRED FOR INSTALLATION .....	23
<b>4. CHARGING STATION - PACKAGE CONTENTS .....</b>	<b>24</b>
4.1. SERIES 7/SERIES 8 ISO CHARGER.....	24
4.2. PEDESTAL MOUNTING HARDWARE.....	24
4.2.1. PEDESTAL UNBOXING AND DISASSEMBLY .....	27
4.3. WALL MOUNTING HARDWARE .....	30

<b>5. CHARGING STATION INSTALLATION.....</b>	<b>33</b>
<b>5.1. PEDESTAL INSTALLATION INSTRUCTIONS.....</b>	<b>33</b>
5.1.1. SITE LOCATION .....	33
5.1.2. PEDESTAL DRILLING TEMPLATE INSTALLATION .....	34
5.1.3. PEDESTAL INSTALLATION .....	37
5.1.4. HEAD UNIT INSTALLATION .....	41
<b>5.2. WALL MOUNT INSTALLATION .....</b>	<b>43</b>
5.2.1. SITE LOCATION .....	43
5.2.2. PREPARING THE WALL.....	44
5.2.3. WALL MOUNT BRACKET INSTALLATION.....	46
5.2.4. CABLE HANGER INSTALLATION .....	47
5.2.5. HEAD UNIT INSTALLATION .....	47
<b>5.3. CONNECTING INPUT WIRING .....</b>	<b>49</b>
5.3.1. HOLSTER PANEL ASSEMBLY.....	51
<b>5.4. DERATE SWITCH .....</b>	<b>52</b>
<b>6. CABLE MANAGEMENT SYSTEM (CMS) - PACKAGE CONTENTS.....</b>	<b>54</b>
<b>6.1. PEDESTAL MOUNT CABLE MANAGEMENT SYSTEM.....</b>	<b>54</b>
<b>6.2. WALL MOUNT CABLE MANAGEMENT SYSTEM .....</b>	<b>57</b>
<b>7. CABLE MANAGEMENT SYSTEM (CMS) INSTALLATION .....</b>	<b>59</b>
<b>7.1. SERIES 7/SERIES 8 ISO CHARGER WITH CABLE MANAGEMENT SYSTEM - PEDESTAL INSTALLATION</b>	
<b>59</b>	
7.1.1. SITE LOCATION .....	59
7.1.2. CABLE MANAGEMENT SYSTEM DRILLING TEMPLATE INSTALLATION .....	60
7.1.3. CABLE MANAGEMENT SYSTEM PEDESTAL INSTALLATION.....	62
7.1.4. CMS CABLE CLAMP INSTALLATION.....	66
<b>7.2. SERIES 7/SERIES 8 ISO CHARGER WITH CABLE MANAGEMENT SYSTEM – WALL MOUNT</b>	
<b>INSTALLATION .....</b>	<b>67</b>
7.2.1. SITE SELECTION .....	67
7.2.2. PREPARING THE WALL.....	68
7.2.3. CMS WALL MOUNT BRACKET INSTALLATION .....	69
7.2.4. CMS WALL MOUNT HEAD UNIT INSTALLATION .....	70
7.2.5. CMS CABLE CLAMP INSTALLATION.....	72

---

<b>8.</b>	<b><u>COMMISSIONING AND ENERGIZATION</u></b> .....	<b>74</b>
<b>8.1.</b>	<b>STATION COMMISSIONING</b> .....	<b>74</b>
<b>8.2.</b>	<b>INITIAL POWER-UP SEQUENCE</b> .....	<b>74</b>
<b>9.</b>	<b><u>OPERATING INSTRUCTIONS</u></b> .....	<b>75</b>
<b>9.1.</b>	<b>OPERATING PRECAUTIONS</b> .....	<b>75</b>
<b>9.2.</b>	<b>OPERATING INSTRUCTIONS</b> .....	<b>76</b>
<b>9.2.1.</b>	<b>INITIALIZATION AND IDLE STATE</b> .....	<b>76</b>
<b>9.2.2.</b>	<b>USER AUTHORIZATION</b> .....	<b>78</b>
<b>9.2.3.</b>	<b>CHARGING</b> .....	<b>81</b>
<b>9.2.4.</b>	<b>CHARGING COMPLETE</b> .....	<b>82</b>
<b>9.3.</b>	<b>OPERATING STATUS</b> .....	<b>83</b>
<b>9.4.</b>	<b>CUSTOMER SUPPORT</b> .....	<b>83</b>
<b>10.</b>	<b><u>TROUBLESHOOTING</u></b> .....	<b>83</b>
<b>11.</b>	<b><u>CLEANING AND MAINTENANCE</u></b> .....	<b>85</b>
<b>12.</b>	<b><u>WARRANTY</u></b> .....	<b>85</b>

## 1. SAFETY AND COMPLIANCE

This document provides instructions to install the Blink Charging Station and should not be used for any other products. This product must be installed in accordance with the National Electrical Code (NEC), the Canadian Electrical Code (CEC) or any applicable local code.

Review this manual and consult a licensed contractor and/or electrician before installation to ensure compliance with local building practices, climate conditions, safety standards, and state and local codes.

The Blink Charging Station should be installed by a licensed contractor/ electrician and inspected by a qualified installer prior to initial use. Under no circumstances will compliance with the information in this manual relieve the user of responsibility to comply with all applicable codes and safety standards.

This document describes the most common installation and mounting methods. Contact Blink where it is not possible to perform an installation using the procedures provided in this document.

Blink is not responsible for damage that may occur or result from installations that are not described in this document. This document is not offered as a formal design document. All designs for the installation of this product are the sole responsibility of the appropriately licensed and/or certified installing contractor.

The following signs are used throughout the installation manual following ANSI Z535 Standard:

Sign	Intended Use
	<i>Situation will result in serious injury or death</i>
	<i>Situation could result in serious injury or death</i>
	<i>Situation could result in moderate or minor injury</i>
	<i>Situations that at worst will result in property damage and will not result in physical injuries</i>

**DANGER** NOTE: MAKE SURE TO TURN OFF ALL BREAKERS BEFORE DOING ANY ELECTRICAL WORK!



## 1.1. GENERAL

The Blink Station is grounded through a dedicated conductor to the ground connection at the power distribution panel. This equipment has been tested and found to comply with the limits for a Class A digital device, pursuant to Part 15 of the FCC rules. These limits are designed to provide reasonable protection against harmful interference when the equipment is operated in a commercial environment.

### NOTICE

The equipment generates, uses, and can radiate radio frequency energy and, if not installed and used in accordance with the instruction manual, may cause harmful interference to radio communications.

## 1.2. STATEMENTS

Reasonable effort has been made to ensure that the specifications and other information in this manual are accurate and complete at the time of publication. However, specifications and other information in this manual are subject to change at any time without prior notice.

### NOTICE

Use of the Blink Charging Station in a manner not intended or any modification not approved by the manufacturer will void the limited warranty. Other than the limited product warranty provided by Blink, this manual and the Blink Inc. products are provided "AS IS," and Blink Inc. expressly disclaim all implied warranties, including any warranty of design, merchantability, and fitness for a particular purposes and non-infringement, to the maximum extent permitted by law.

### NOTICE

*IN NO EVENT SHALL BLINK INC. OR ITS AUTHORIZED DISTRIBUTORS BE LIABLE FOR ANY INDIRECT, INCIDENTAL, SPECIAL, PUNITIVE, OR CONSEQUENTIAL DAMAGES, INCLUDING WITHOUT LIMITATION, LOST PROFITS, LOST DATA, LOSS OF USE, COST OF COVER, OR LOSS OR DAMAGE TO THE BLINK CHARGING STATION ARISING OUT OF OR RELATING TO THE USE OR INABILITY TO USE THIS MANUAL, OR RELATED PRODUCT, EVEN IF BLINK OR ITS AUTHORIZED DISTRIBUTORS HAVE BEEN ADVISED OF THE POSSIBILITY OF SUCH DAMAGES.*

All products or services mentioned are the trademarks, service marks, registered trademarks, or registered service marks of their respective owners. This material is protected by the copyright laws of the United States and other countries. It may not be modified, reproduced, or distributed without the prior, express written consent of Blink Network, LLC.

## 2. SYSTEM OVERVIEW

### 2.1. PRODUCT SPECIFICATIONS

ELECTRICAL SPECIFICATION – AC OUTPUT	
Number of Ports	One or Two <i>(Model 748 – Two only)</i>
Current	Configurable up to 80A per port <i>(Model 748 - configurable up to 48A per port)</i>
Power	Up to 19.2 kW per port @ 240 VAC; Up to 16.64kW per port @ 208 VAC <i>(Model 748 - up to 11.52kW per port @ 240 VAC, up to 9.98kW per port @ 208 VAC)</i>
Energy Metering Accuracy	+/- 1 %
Charging Connector	J1772 or NACS
ELECTRICAL SPECIFICATION – AC INPUT	
Input Connector	Hardwired
Voltage	208/240VAC
Service Panel Breaker	1 or 2x 100A max depending on output configuration <i>(Model 748 – 1 or 2x 60A max)</i>
Power Connection	Line 1, Line 2, and Ground (no Neutral) per port
Standby Power	4.6W per port
SAFETY SPECIFICATION	
Ground Fault Circuit Interrupt	20mA CCID with auto-retry
Automatic Plug- Out Detection	Power terminated per SAE J1772 spec
Surge Protection	6kV @ 3,000A
FUNCTIONAL SPECIFICATION	
Connectivity	Cellular 4G LTE, Wi-Fi, Ethernet
Backend Protocol	OCPP 1.6J compliant
Remote Management	Remote access, diagnostics, Over-the-Air (OTA) software update enabled
Load Management	Smart, dynamic allocation and distribution of power to each port
USER INTERACTION SPECIFICATION	
Charging Status Indicator	High-visibility, multi-color visual status indication
Display	4.3" color LCD screen, 480x272
Authentication	RFID: ISO14443 Type A & B, MiFare, Felica, ISO15693 NFC: Apple VAS, NEMA, Google Smart Tap Plug and Charge: ISO 15118 ready
Payment	RFID card, Mobile app Optional: Apple/Google Pay, Contactless/Magnetic/EMV Credit Card (Model 880 only)
ENVIRONMENTAL SPECIFICATION	
Enclosure	Aluminum, UL Type 3R

Operating Humidity	Up to 95% non-condensing
Operating Temperature	-30 degrees C to +50 degrees C
Operating Altitude	<=6560 ft
<b>MECHANICAL SPECIFICATION</b>	
Dimensions	Model 780/748 Head Unit: 18.0" H x 7.4" W x 7.4" D Model 880 Head Unit: 22.5" H x 7.4" W x 9.7" D Pedestal: 35" H x 12.5" W x 8.1" D Wall Mount: 14.7" H x 8.6" W x 7.7" D
Approximate Weights	Model 780 Head Unit: 42.7 lbs Model 880 Head Unit: 44.7 lbs Model 748 Head Unit: 34.5 lbs Pedestal: 24.2 lbs Wall Mount: 16.3 lbs
Mounting Option	Wall or Pedestal mount
Cable Length	23 ft (Model 748 – 25 ft)
Cable Management System	Optional
<b>REGULATION</b>	
Safety	UL 2594 / CSA C22.2 No. 280-16, UL 2231-1 / CSA C22.2 No. 281.1-12, UL 2231-2 / CSA C22.2 No. 281.2-12 certified
EMI	FCC Part 15 Class A Compliant
Energy Efficiency	Energy Star Certified
Compliance	California Type Evaluation Program (CTEP) certified NEVI compliant (Model 880 only)
Accessibility	ADA Compliant

## 2.2. PRODUCT DIMENSIONS

### 2.2.1. Series 7 – ISO Charger with Pedestal dimensions:

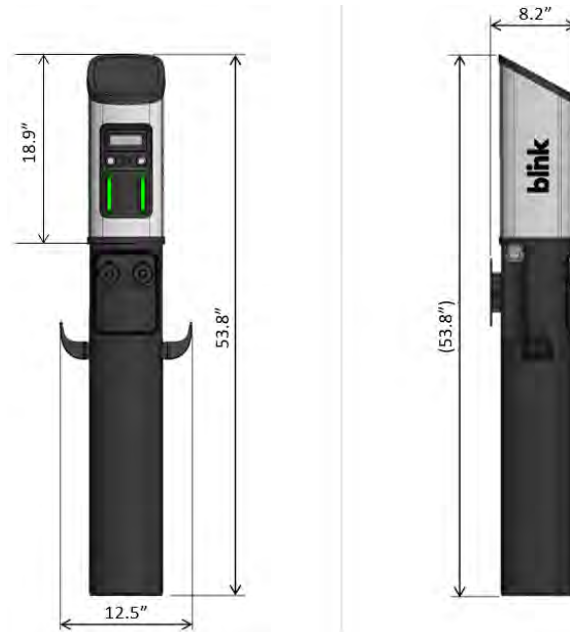

Fig. 1 - Series 7 - ISO charger with pedestal

**2.2.2. Series 8 - ISO Charger with Pedestal dimensions:**

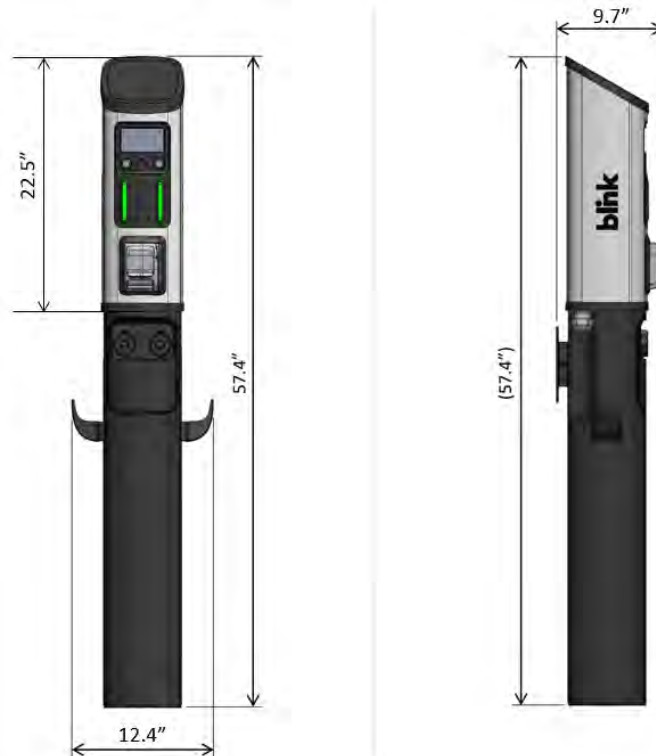

Fig. 2 - Series 8 - ISO charger with pedestal

**2.2.3. Series 7 - ISO Charger with Wall Mount dimensions:**

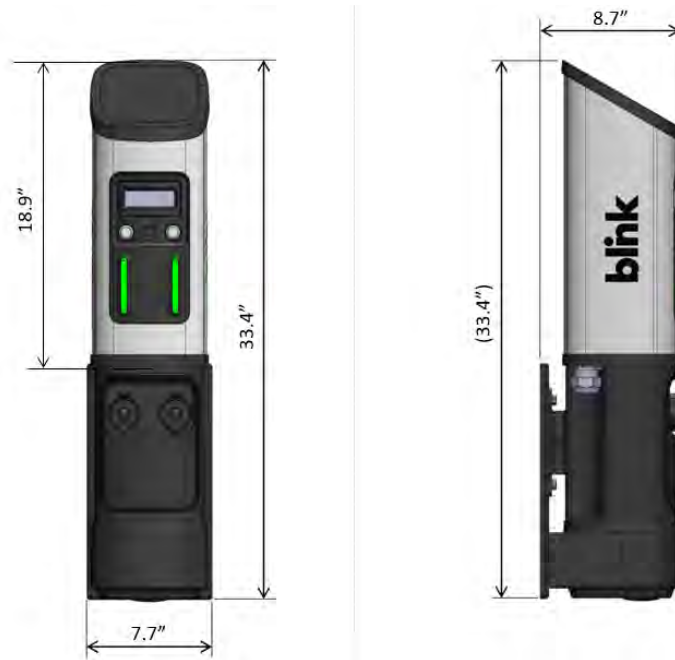

Fig. 3 - Series 7 - ISO charger with wall mount

**2.2.4. Series 8 - ISO Charger with Wall Mount dimensions:**

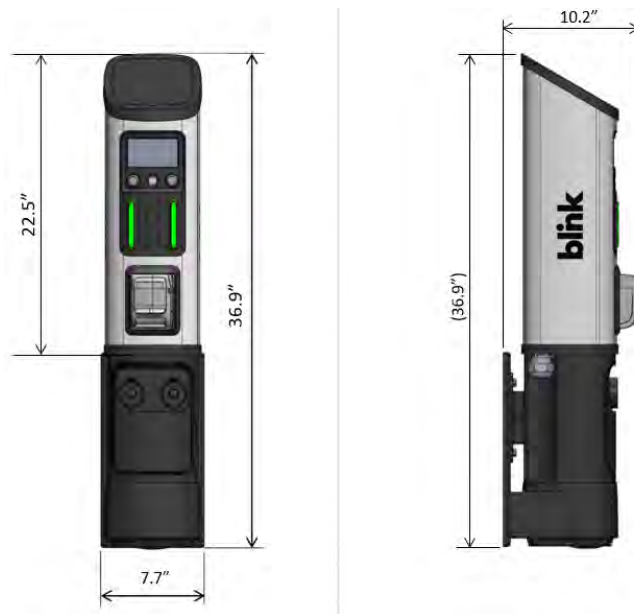

Fig. 4 - Series 8 - ISO charger with wall mount

**2.2.5. Series 7 - ISO Charger with Pedestal and Cable Management System:**

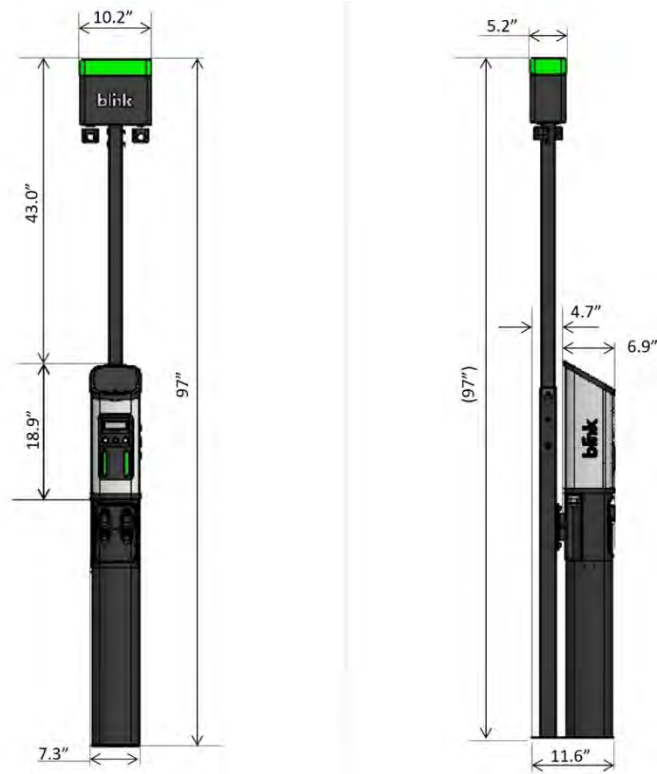

Fig. 5 - Series 7 - ISO charger with pedestal and cable management system

**2.2.6. Series 8 - ISO Charger with Pedestal and Cable Management System:**

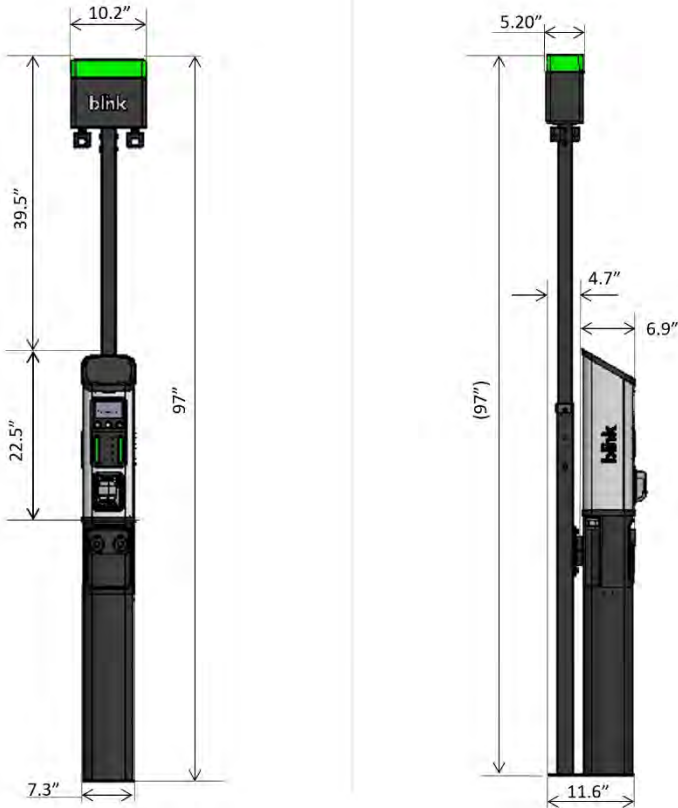

Fig. 6 - Series 8 - ISO charger with pedestal and cable management system

**2.2.7. Series 7 – ISO Charger with Wall Mount and Cable Management System:**

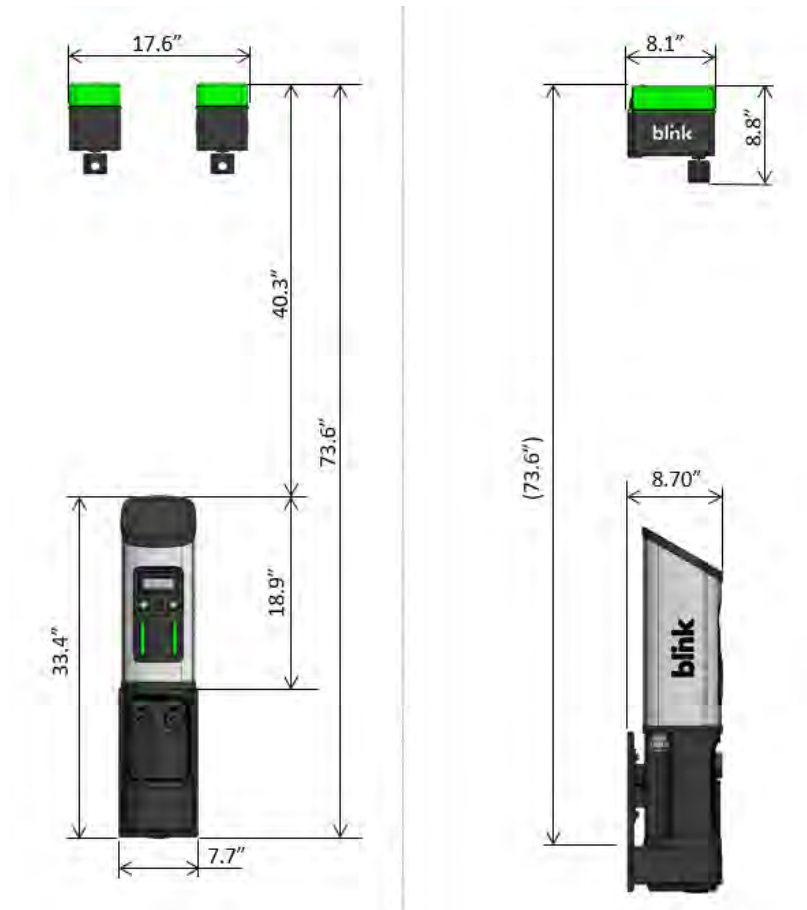

Fig. 7 – Series 7 – ISO charger with wall mount and cable management system

**2.2.8. Series 8 – ISO Charger with Wall Mount and Cable Management System:**

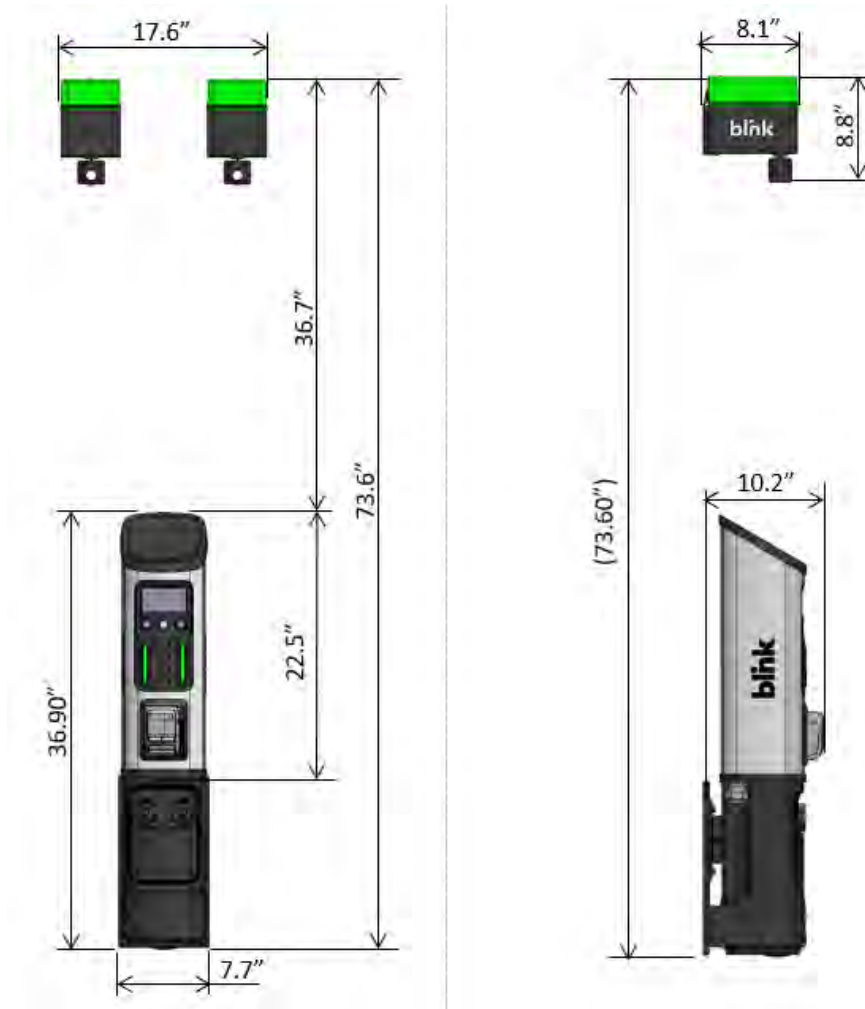

Fig. 8 – Series 8 – ISO charger with wall mount and cable management system

### 3. PLANNING AND DESIGN

#### 3.1. ELECTRICAL REQUIREMENTS

##### **⚠ WARNING**

**Blink EV charging stations require a solidly grounded electrical system with the presence of a main bonding jumper or system bonding jumper. Ungrounded sources or impedance grounded sources of any type (resistor/reactor) are not suitable for Blink EV charging stations.**

- The Series 7 and Series 8 charging stations require 240-volt (phase to phase) or 208-volt (phase to phase) input with an equipment grounding conductor.
- A Neutral conductor is not connected to the charger itself, but the Neutral or Center-Tap connection on the service transformer must be connected to Earth Ground.
- The Series 7 and Series 8 charging stations have internal GFCI protection; therefore, GFCI breakers are not needed unless required by local electrical code.

**Connect the Series 7 or Series 8 Charging Stations to any one of the power sources below:**

1. 240 VAC three phase, Delta system, Center tap grounded
2. 208 VAC three phase, Wye system, Bonded neutral
3. 240 VAC single phase, Bonded neutral

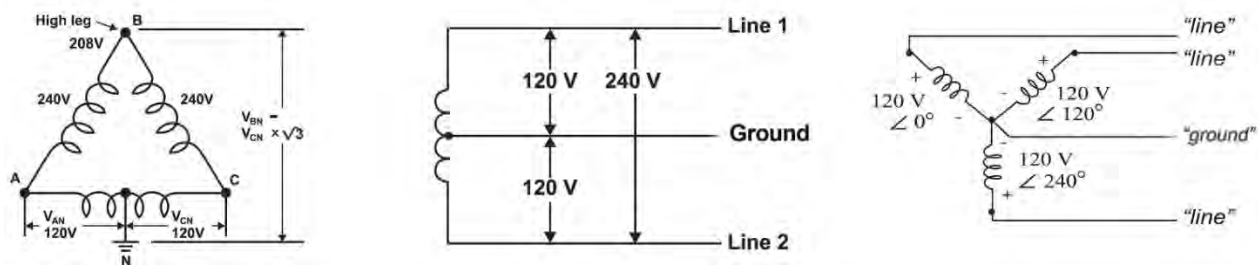

Fig. 9 – Acceptable transformer configurations

In a Wye system, connect the charging stations to any of the two lines. Do not use the system if it has a floating ground.

In a Delta system, connect the charging station only to a center-tapped grounded transformer as

shown above. Connect the station to the side where ground is bonded (Line A and Line C above). This allows voltages to remain constant regardless of other loads on the system.

Please do not connect to other types of Delta transformers, as indicated below.

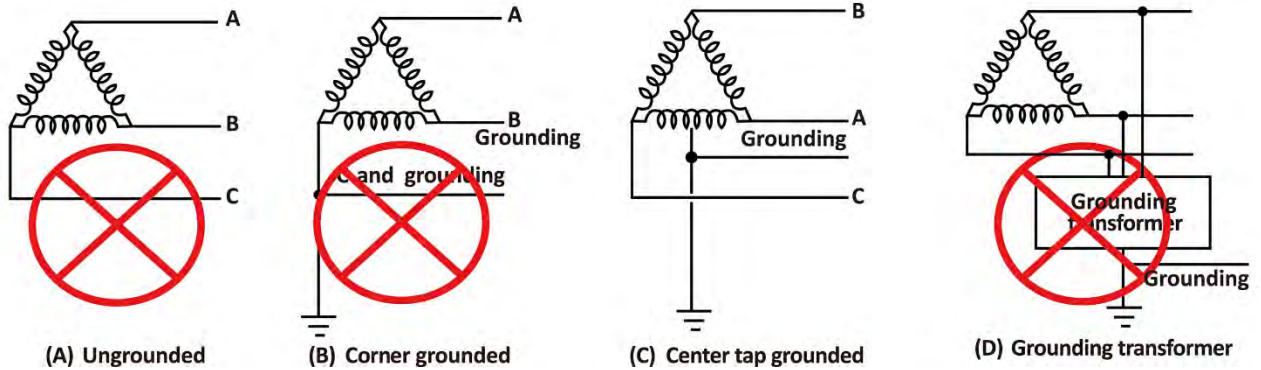

Fig. 10 - Unacceptable Delta transformer configurations

**⚠ WARNING**

Each Blink EV charging station is listed and labeled through Nationally Recognized Testing Laboratory compliance testing at the maximum or 'full rated' output. Each station is capable of continuous full rated output up to its labeled rating or modified default output configurations in accordance with the following tables:

SERIES 7+/8+ 80 AMP - DUAL SOURCE INPUT CONFIGURATION

SERIES 7+/8+ (80 AMPS)			
240V or 208V DUAL SOURCE INPUT	TWO-POLE BREAKER SIZE	MODIFIED OUTPUT CONFIGURATION REQUIRED	AMPERAGE OUTPUT
	100A	NO	80A
	90A	YES	72A
	80A	YES	64A
	70A	YES	56A
	60A	YES	48A
	50A	YES	40A
	40A	YES	32A
	30A	YES	24A
	20A	YES	16A
	15A	YES	12A

Table 1 - Circuit breaker ratings for dual-source input configurations

SERIES 7+/8+ 80 AMP - SINGLE SOURCE INPUT CONFIGURATION

**MODIFIED OUTPUT CONFIGURATION OR LOAD MANAGEMENT REQUIRED**

SERIES 7+/8+ (80 AMPS)			
240V or 208V SINGLE SOURCE INPUT	TWO-POLE BREAKER SIZE	MODIFIED OUTPUT CONFIGURATION OR LOAD MANAGEMENT REQUIRED	AMPERAGE OUTPUT
	100A	YES	80A
	90A	YES	72A
	80A	YES	64A
	70A	YES	56A
	60A	YES	48A
	50A	YES	40A
	40A	YES	32A
	30A	YES	24A
	20A	YES	16A
	15A	YES	12A

Table 2 - Circuit breaker ratings for single-source input configurations

### 3.2. STATION CONNECTION DIAGRAMS

**⚠ WARNING**

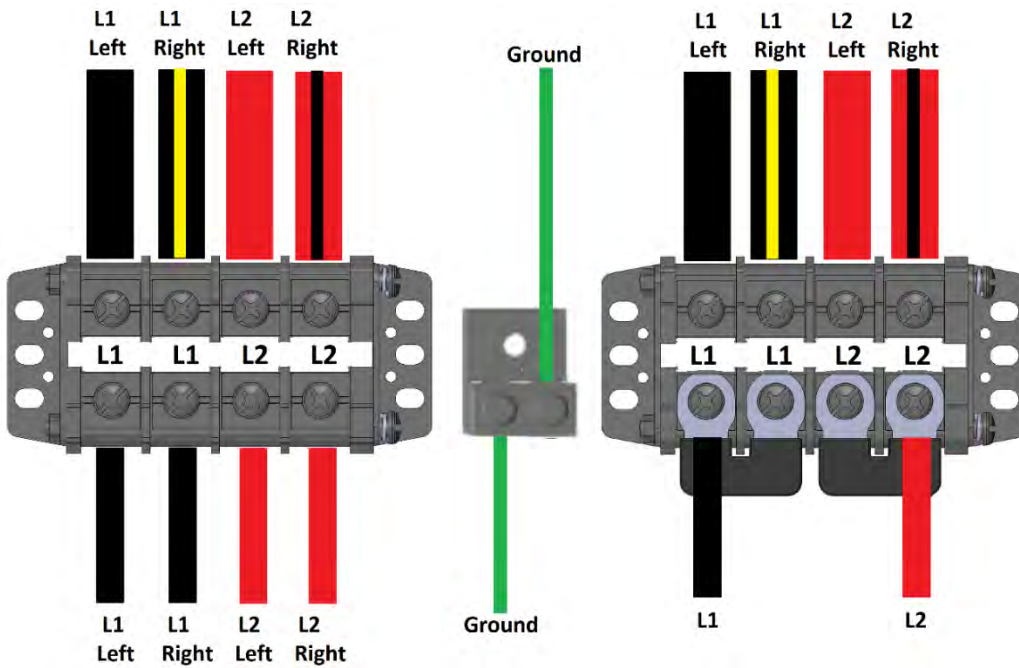

Dual Source Input Wiring

Single Source Input Wiring

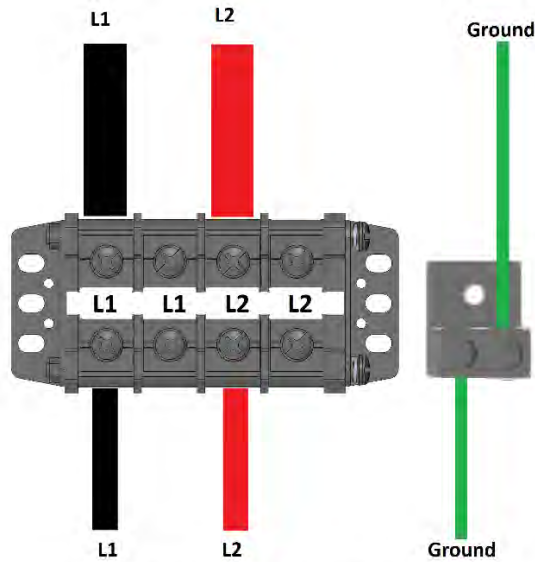

Single Port Input Wiring

Fig. 11 – AC input connection diagrams

### 3.3. COMMUNICATION REQUIREMENTS

- **⚠ CAUTION** The equipment generates, uses, and can radiate radio frequency energy and, if not installed and used in accordance with the instruction manual, may cause harmful interference to radio communications.
- **NOTICE** This equipment has been tested and found to comply with the limits for a Class A digital device, pursuant to Part 15 of the FCC rules. These limits are designed to provide reasonable protection against harmful interference when the equipment is operated in a commercial environment.
- The Series 7 and Series 8 EV charging stations require cellular, WiFi, or ethernet connectivity to function properly. It is recommended to check cellular and WiFi signal strength before charger installation.
- To enable cellular connectivity, please reference the following cellular carriers and minimum operational signal requirement at each EV charging station location:

ATT or T-Mobile	4G LTE	Band 2 Band 4 Band 5 Band 12 Band 13
Verizon	4G LTE	Band 4 Band 13

Table 3 – Cellular carriers and bands

- Stations are shipped with a SIM card for one of the above carriers. Client must verify signal levels for all carriers and notify Blink prior to order shipment if a specific carrier is required.
- Recommended cellular signal strength values are RSRP  $\geq$  -80 dBm and RSRQ  $\geq$  -10 dB. See the table below for reference:

Signal Strength	RSRP (dBm)	RSRQ (dB)
Excellent	$\geq$ -80	$\geq$ -10
Good	-80 to -90	-10 to -15
Fair	-90 to -100	-15 to -20

Table 4 – Cellular signal strength requirements

- Ethernet and RS 485 connections are available on the bottom of the head unit (see below).
- When the station is connected via an Ethernet cable, no additional setup is required.
- **NOTICE** Ethernet and RS 485 wiring must be run in a separate conduit from the AC input power wires.

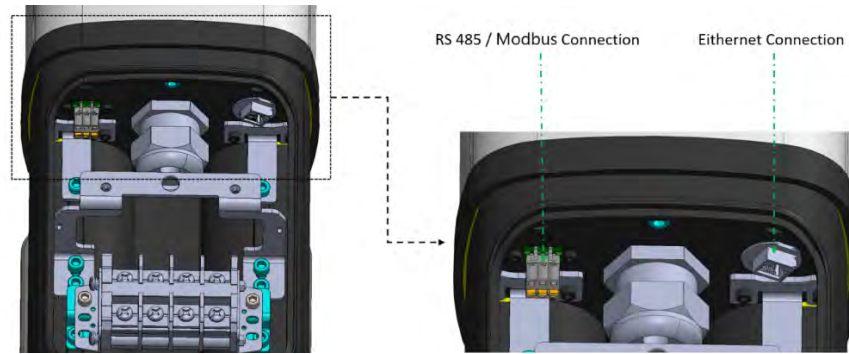

Fig. 12 – RS 485 and Ethernet port locations

For assistance with setting up WiFi communication, or for additional questions related to charging station communication, please contact [designservice@blinkcharging.com](mailto:designservice@blinkcharging.com).

### 3.4. NETWORK PLATFORM REQUIREMENTS

#### **NOTICE**

To enable modified output configurations or load management configurations, Blink must be notified during station commissioning. Failure to do so may result in nuisance breaker tripping and/or system damage. Refer to the Station Commissioning section of this manual (Section 8.1) for details.

### 3.5. TOOLS REQUIRED FOR INSTALLATION

**Note: Does not include tools required for installation of electrical conduit**

Tool	Notes
Metric Allen Keys (2mm, 4mm, 5mm, 6mm)	
Right angle driver with 6mm hex bit	(Optional) for pedestal installation
#3 Philips screwdriver	
1/4" straight screwdriver	
3/4" socket or box wrench	Required if using J-bolts for Pedestal Installation
Wire Stripping tool	For 2 AWG (80A version) or 6 AWG (48A version)
Wire Crimping tool	For 2 AWG and 6 AWG non-insulated ring terminals
Masonry drill bit(s)/driver	Size varies depending on anchor(s) used

Table 5 – Tools Required for Installation

---

## 4. CHARGING STATION - PACKAGE CONTENTS

### 4.1. SERIES 7/SERIES 8 ISO CHARGER

Series 7/Series 8 ISO Charging Station Head Unit

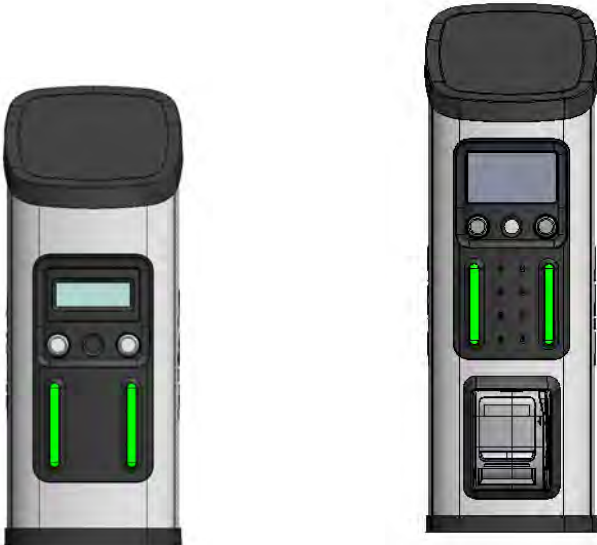

### 4.2. PEDESTAL MOUNTING HARDWARE

Series 7/Series 8 ISO Pedestal



Pedestal Drilling Template - Qty 1



M12 Concrete Anchors - Qty 4

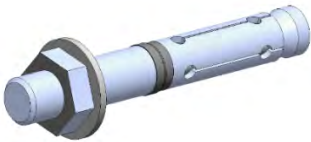

Head Unit Mounting Screws:

- Rear head unit mounting screws (Allen Cap M6x10mm) - Qty 2
- Bottom front head unit mounting screw (Allen Cap M6x25mm) - Qty 1

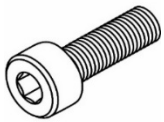

T10 Tamper-Resistant Torx Driver Bit - Qty 1

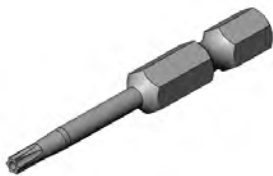

T30 Tamper-Resistant Torx Driver Bit - Qty 1



2 AWG Ring Terminals - Qty 4



Shorting Jumpers for Terminal Block (**to be used only in Shared Power configuration**) - Qty 2



### 4.2.1. Pedestal Unboxing and Disassembly

Unbox and disassemble the Pedestal unit as shown below:

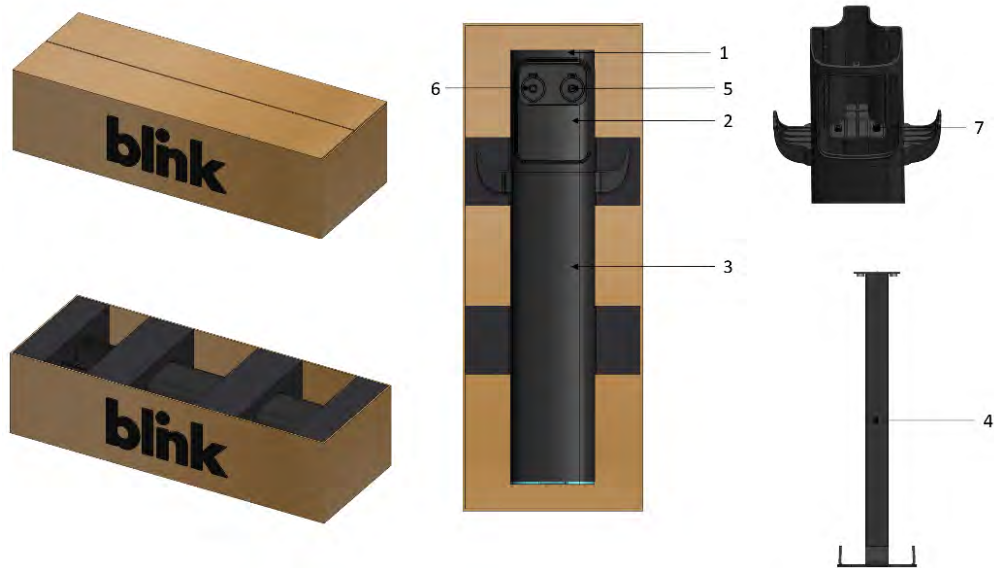

Fig. 13 – Pedestal components

Please make sure that the box contains the following items.

Item	Description	Quantity
1	Pedestal Top Enclosure	1
2	Dual Holster Access Panel	1
3	Pedestal Bottom Enclosure	1
4	Pedestal Base	1
5	M6 x 12mm T30 Tamper-Resistant Torx screw with spring washer	2
6	Silicon Rubber Cap	2
7	M8 x 20mm Allen cap screw with spring washer	2

Table 6 – Pre-assembled pedestal components



Fig. 14 – Remove Dual Holster Access Panel (2x T30 Tamper-Resistant Torx screws)

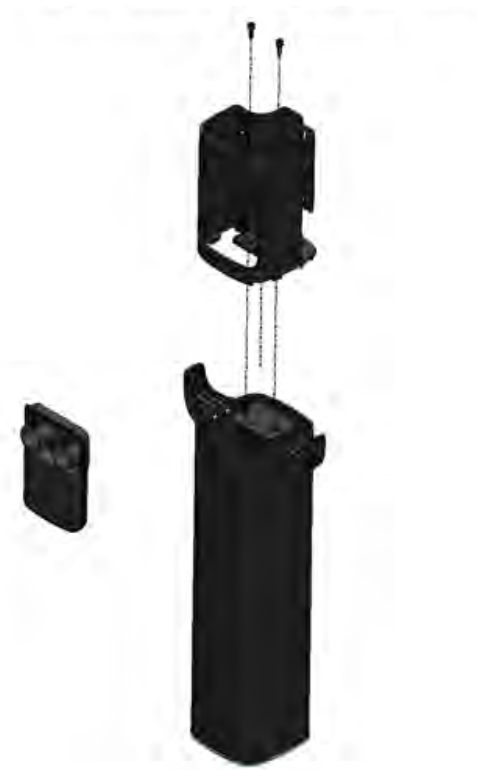

Fig. 15 – Remove Pedestal Top Enclosure (2x M8 Allen cap screws)

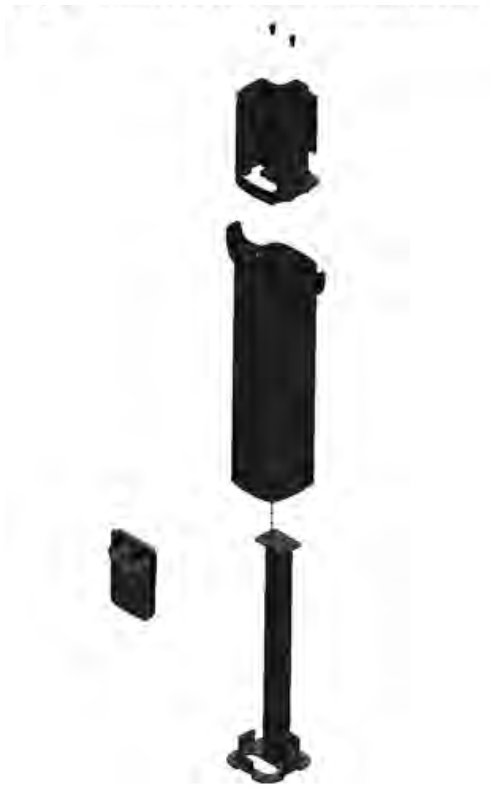
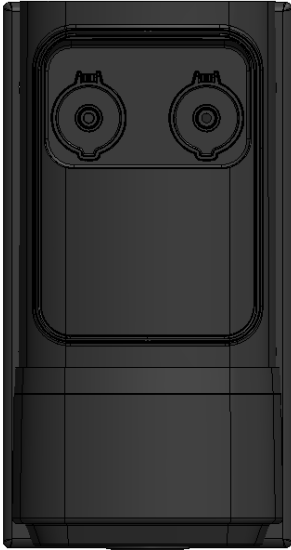

Fig. 16 - Remove Pedestal Bottom Enclosure

### 4.3. WALL MOUNTING HARDWARE

Series 7/Series 8 ISO Wall Mount with Bracket



Cable hanger - Qty 2



Cable hanger Wall bracket - Qty 2

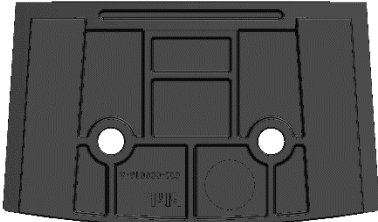

M12 concrete anchor bolts - Qty 4

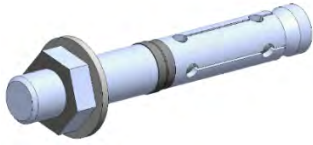

Head Unit Mounting Screws:

- Rear head unit mounting screws (Allen Cap M6x10mm) - Qty 2
- Bottom front head unit mounting screw (Allen Cap M6x25mm) - Qty 1

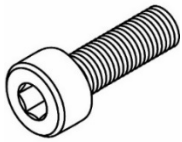

T10 Tamper-Resistant Torx Driver Bit - Qty 1

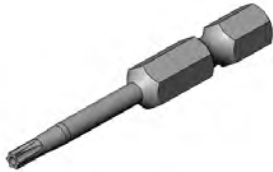

T30 Tamper-Resistant Torx Driver Bit - Qty 1



Cable Hanger Mounting Screws (Hex Lag Screws 1/4x2" or M6x50) - Qty 4



Nylon anchors 8x40 - Qty 4



2 AWG Ring Terminals - Qty 4



Shorting Jumpers for Terminal Block (**to be used only in Shared Power configuration**) - Qty 2



## 5. CHARGING STATION INSTALLATION

### 5.1. PEDESTAL INSTALLATION INSTRUCTIONS

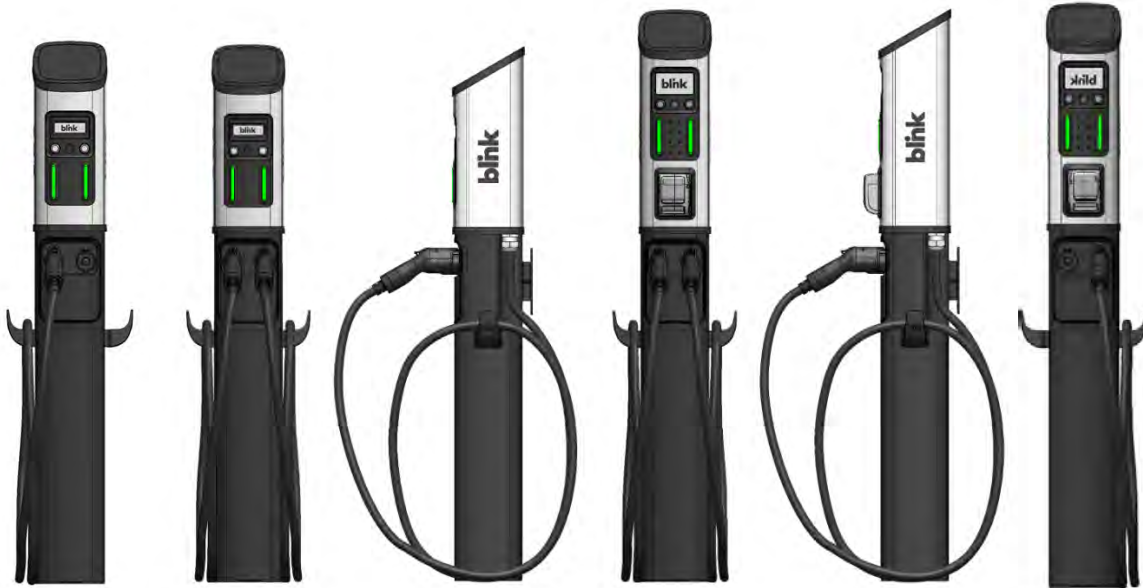

Fig. 17 – Series 7 and Series 8 ISO Pedestal Installation

#### 5.1.1. Site Location

Select the location for the charging station. To mount the charging station, first prepare a concrete pad properly aligned to the parking space. The concrete pad should be positioned such that the distance between the charging station and electric vehicle is enough to minimize the likelihood of damage.

NOTE: Electrical wiring must be run through a conduit inside the concrete pad; the only wire penetration point on the pedestal is through the bottom.

### 5.1.2. Pedestal Drilling Template Installation

**⚠️ WARNING**

**VERIFY ALL CONDUCTORS ARE DE-ENERGIZED**

Note: If installing a Cable Management System and pedestal together on a new concrete pad, the Cable Management System drilling template must be installed at the same time as the Pedestal drilling template. (See Cable Management System installation instructions).

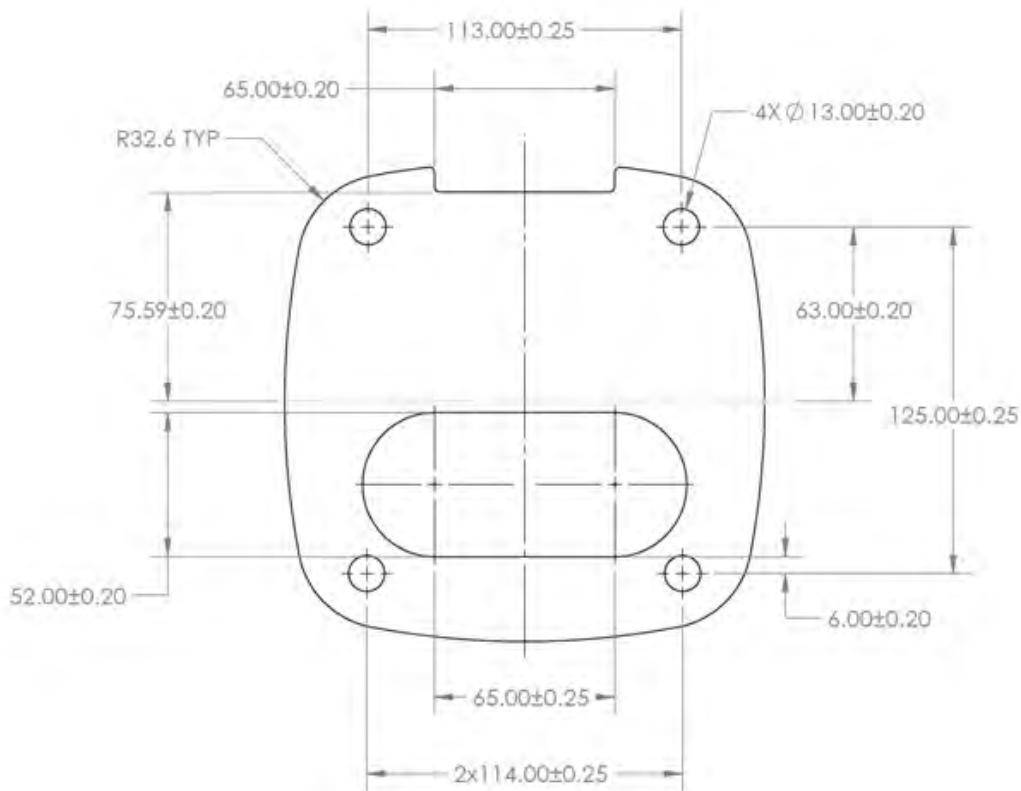

Fig. 18 – Pedestal drilling template dimensions

- Ensure that at least 40" of wire extends out of the conduit (including Ethernet and RS 485 if applicable). Maximum conduit outer diameter is 2".
- Position the Drilling Template so that the conduit location is towards the front side of the Drilling Template (see below).
- Install the Drilling Template using the provided concrete anchors, ensuring the anchors protrude roughly 0.7" above the Drilling Template. The Drilling Template should be flush with the ground.

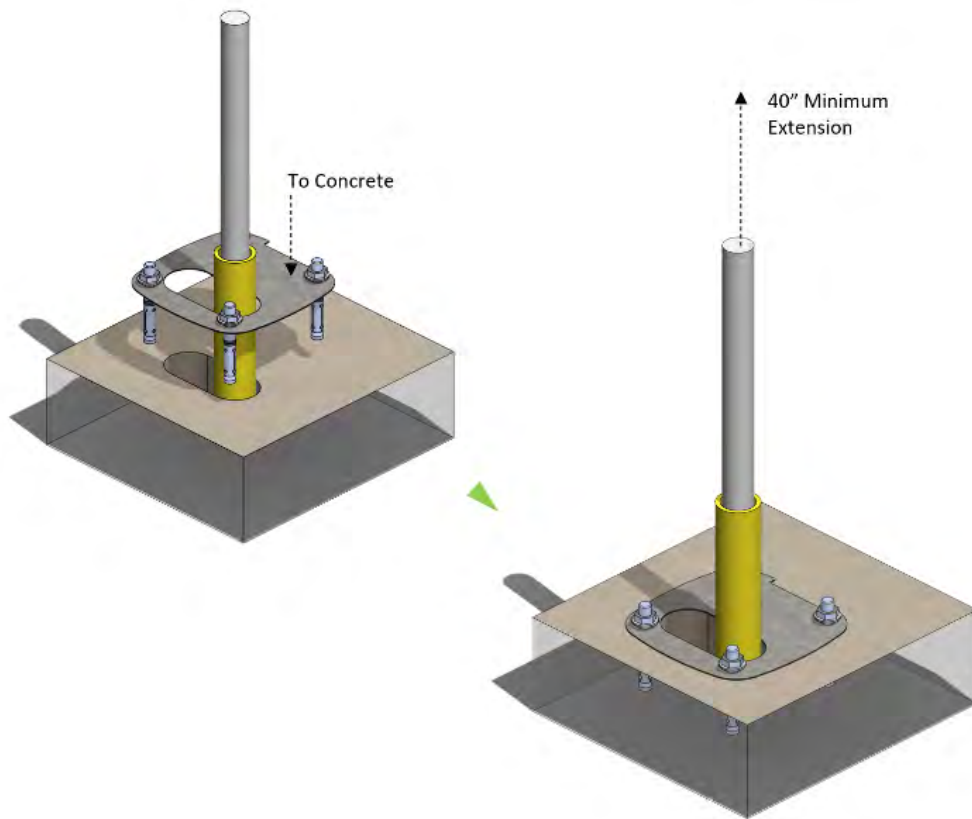

Fig. 19 - Drilling Template installation using concrete anchors



### 5.1.3. Pedestal Installation

#### Install Pedestal Base Assembly:

#### **⚠ WARNING**

#### **VERIFY ALL CONDUCTORS ARE DE-ENERGIZED**

- Remove nuts and washers from anchor bolts.
- Place the Pedestal Base Unit on the Template such that the bolt holes and conduit opening are aligned.
- Ensure that the electric wires are long enough that they can be easily accessed through the access panel opening in the Pedestal's top section.
- Re-install nuts and washers, but do not tighten fully.
- Locate the (4) leveling screws on the pedestal base assembly. Adjust leveling screws to make Pedestal Base plumb (check with Level at two points separated by 90 degrees).
- Gradually tighten anchor bolts to secure the Pedestal Base. Re-check for plumb.

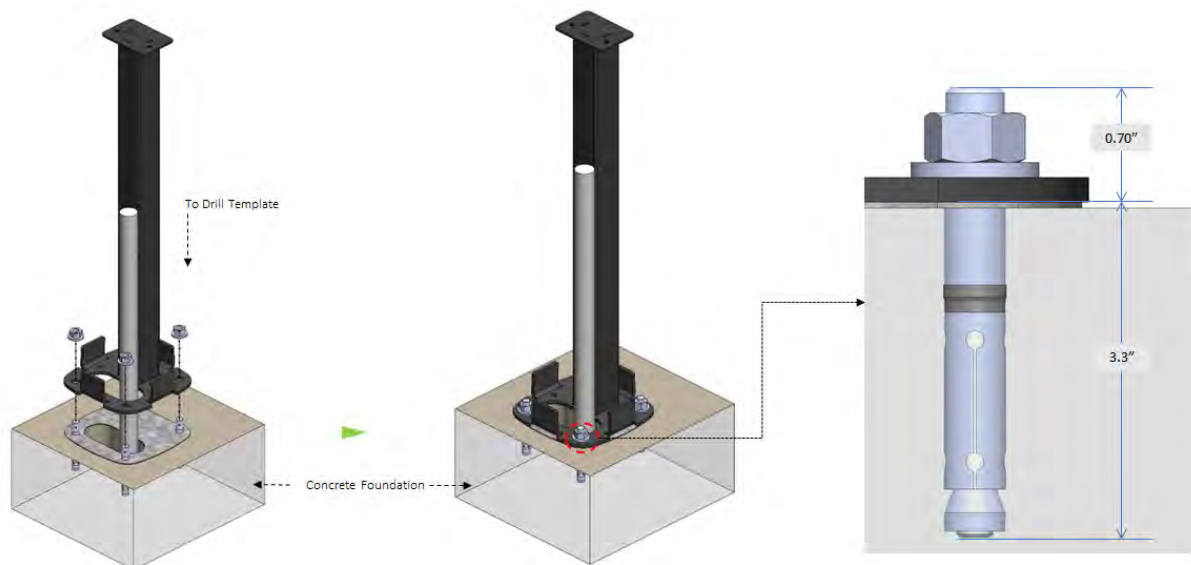

Fig. 20 - Installing pedestal base assembly



Install Pedestal Bottom Enclosure to Pedestal Base Assembly:

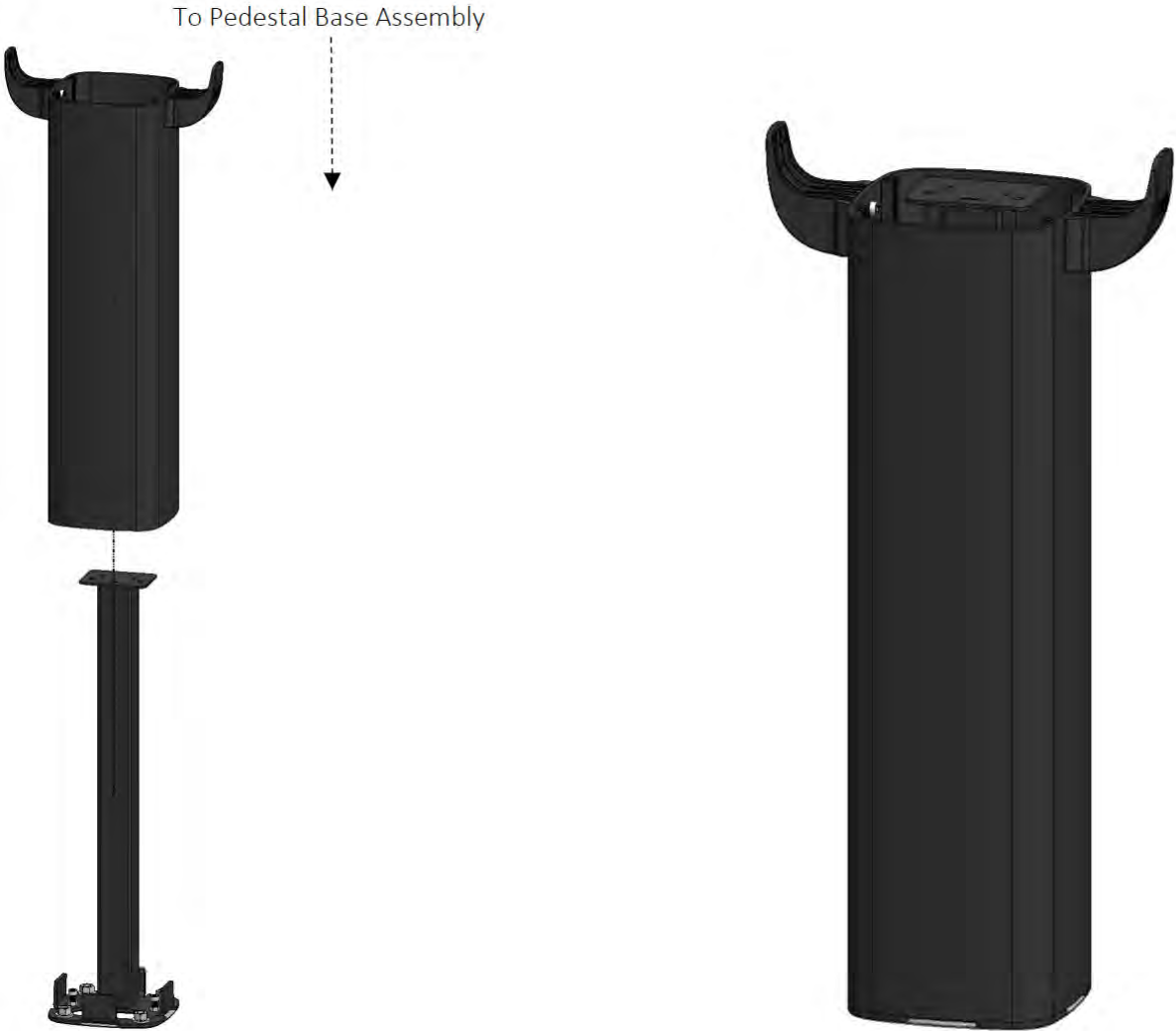

Fig. 21 - Installing pedestal bottom enclosure

**Install Pedestal Top Enclosure to Pedestal Base Assembly:**

Use Allen Cap M8 x 20mm with spring washer to assemble the Pedestal Top Enclosure and Pedestal Bottom Enclosure.



Fig. 22 – Installing pedestal top enclosure to base assembly

### 5.1.4. Head Unit Installation

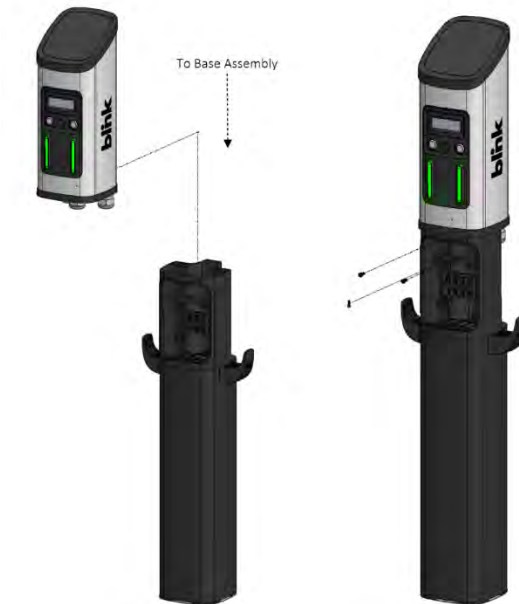

Fig. 23 – Mounting head unit to pedestal assembly

#### **CAUTION**

Refer to General Requirements section for station weights.

- Carefully place the charging station head unit on top of the pedestal as shown in the illustration.
- Align the Guide poles in the pedestal with the base of the head unit.
- Secure the Charging station Head Unit to the Pedestal Unit with the 3 mounting screws (Two from front M6x10mm [1] and one from bottom side M6x25mm [2]).
- Ensure that the charging station is plumb using a level. Check that the Head Unit is now securely fastened to the Pedestal.

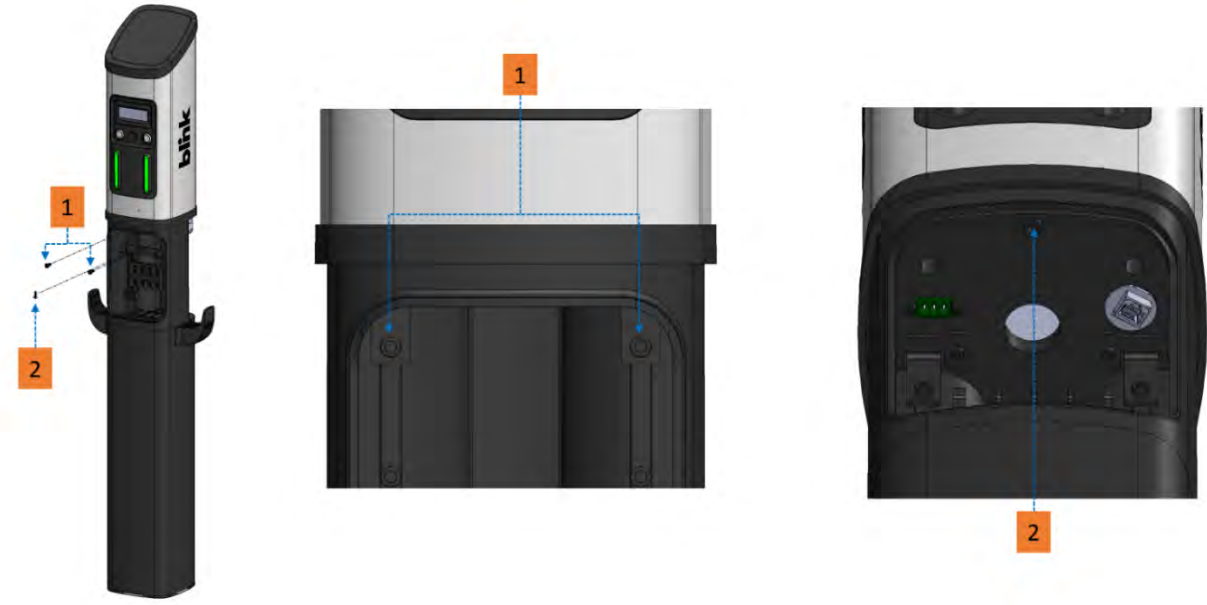

Fig. 24 - Head unit mounting screw locations

**After Pedestal Installation is complete, proceed to “Connecting Input Wiring” section.**

## 5.2. WALL MOUNT INSTALLATION



Fig. 25 – Series 7 and Series 8 ISO Wall Mount Installation

### 5.2.1. Site Location

The charging station should be positioned such that the distance between the charging station and electric vehicle is sufficient to minimize the likelihood of damage (suggested min. 3 ft). Two alternatives are illustrated below:

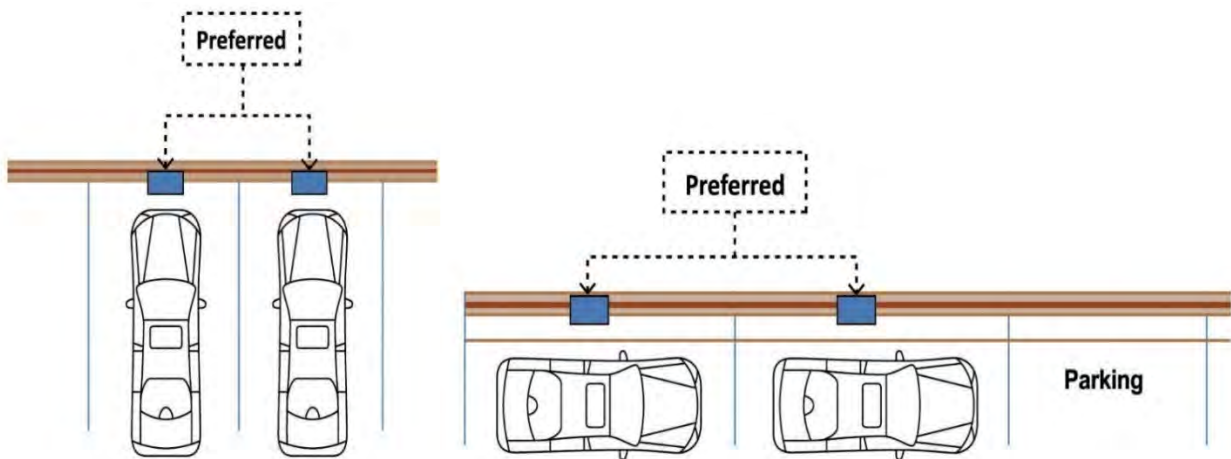

Fig. 26 – Site location recommendations

**5.2.2. Preparing the Wall**

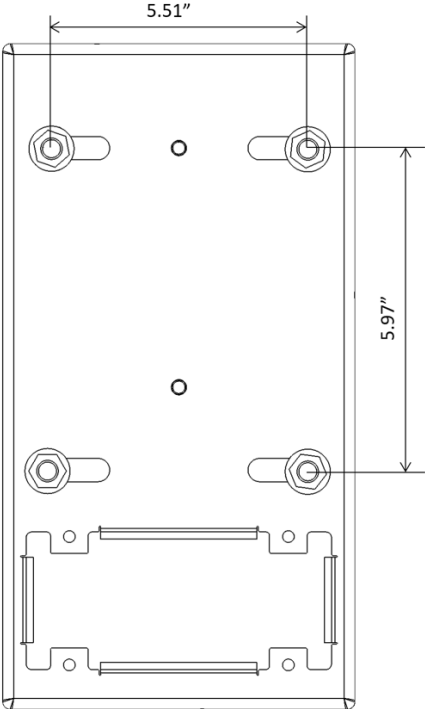

Fig. 27 - Wall Mount bracket template

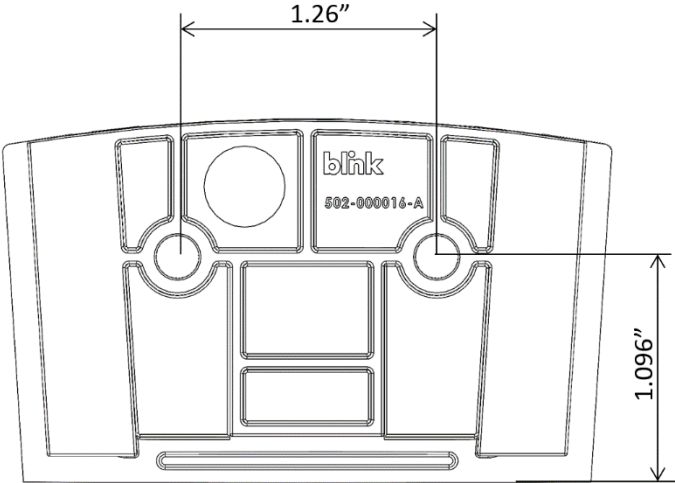

Fig. 28 - Cable hanger bracket template

At the selected location, install the wall mount such that the top of the bracket is at a height of 35 inches (Check local codes).

- The equipment should be installed at least 18 inches above the floor.
- Ensure the wall mount bracket is in an upright position and level.
- Mark locations for the bolts. If the input wiring will enter the wall mount from the rear (through the wall), also mark the conduit penetration location.
- If the wall is made of solid concrete or brick, use anchor bolts to secure the wall-mount to the wall. For walls other than concrete, use fasteners appropriate for the material.
- If the electrical conduit is run on the outside of the wall, use the 2-inch hole on the bottom of the wall mount bracket as the entry point (recommended conduit size 1.5").
- Ensure at least 18" (+ wall thickness for rear entry) of wire extends out of the conduit.

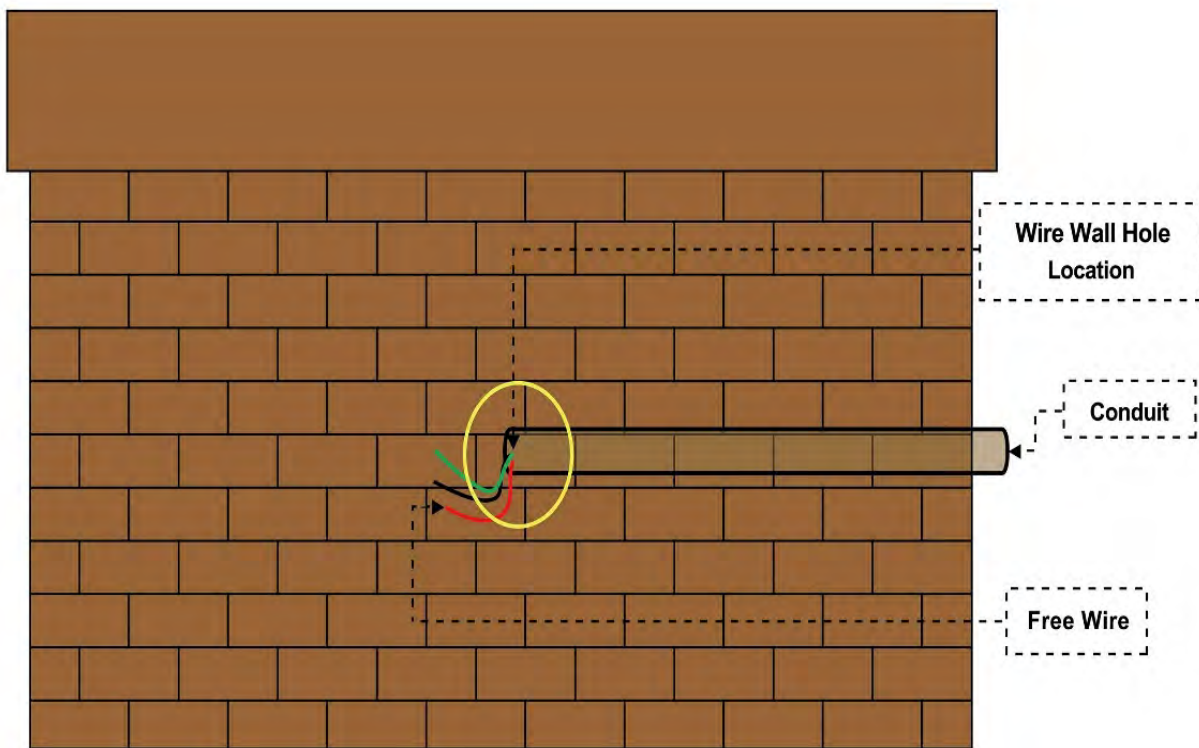

Fig. 29 - Wall preparation

Conduit entry from Bottom:

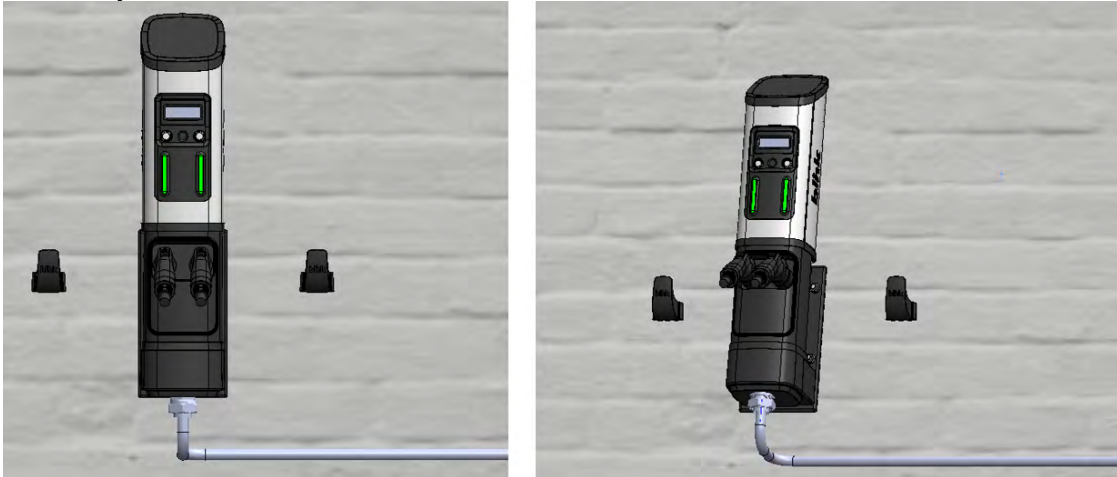

Fig. 30 – Conduit entry location

**5.2.3. Wall Mount Bracket Installation**

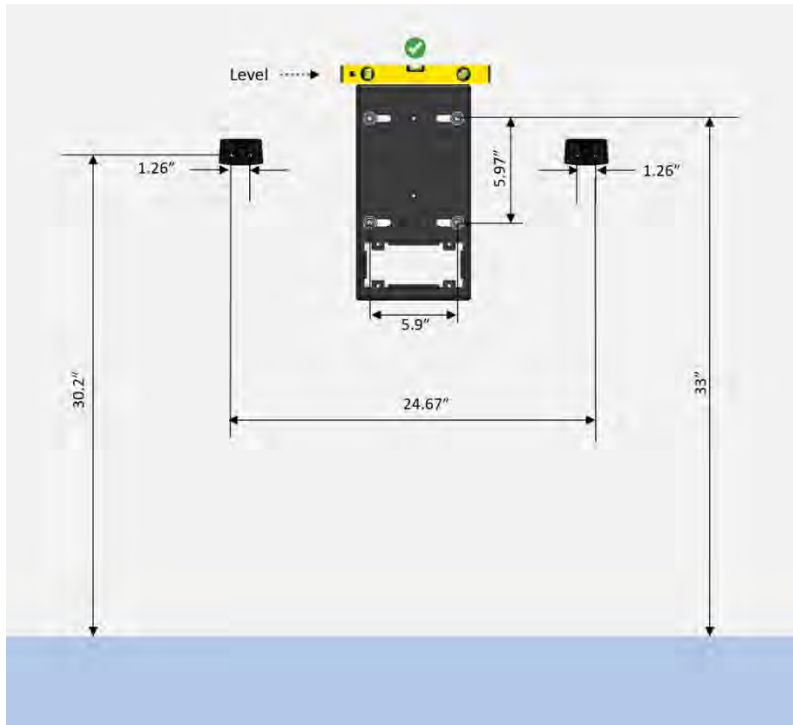

Fig. 31 – Wall mount dimensions

- Now secure the wall-mount with the provided anchor bolts (if concrete or brick wall), or with appropriate fasteners (for other material).

- Secure the Cable hanger wall brackets using the 3/16''' concrete screws with plastic anchors as shown in the above graphic.

### 5.2.4. Cable Hanger Installation

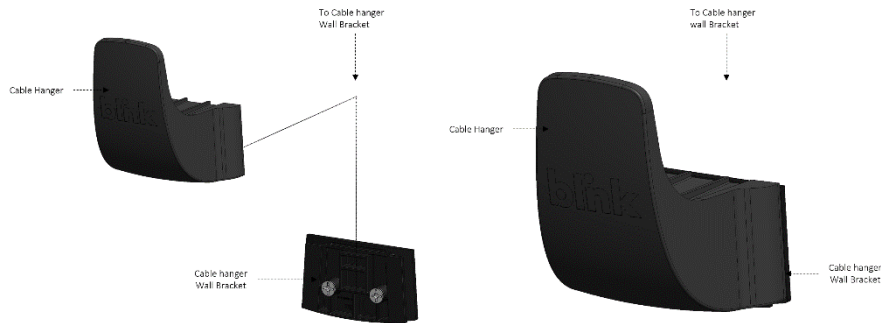

Fig. 32 – Cable hanger wall bracket assembly

- Align the Cable Hanger and Cable Hanger Wall Bracket.
- Install the Cable hanger with a sliding motion from the top to the Cable Hanger Wall Bracket.
- Check that the Cable Hanger is secure and is firmly attached to the Cable Hanger Wall Bracket.

### 5.2.5. Head Unit Installation



Fig. 33 – Head unit mounting to wall mount bracket

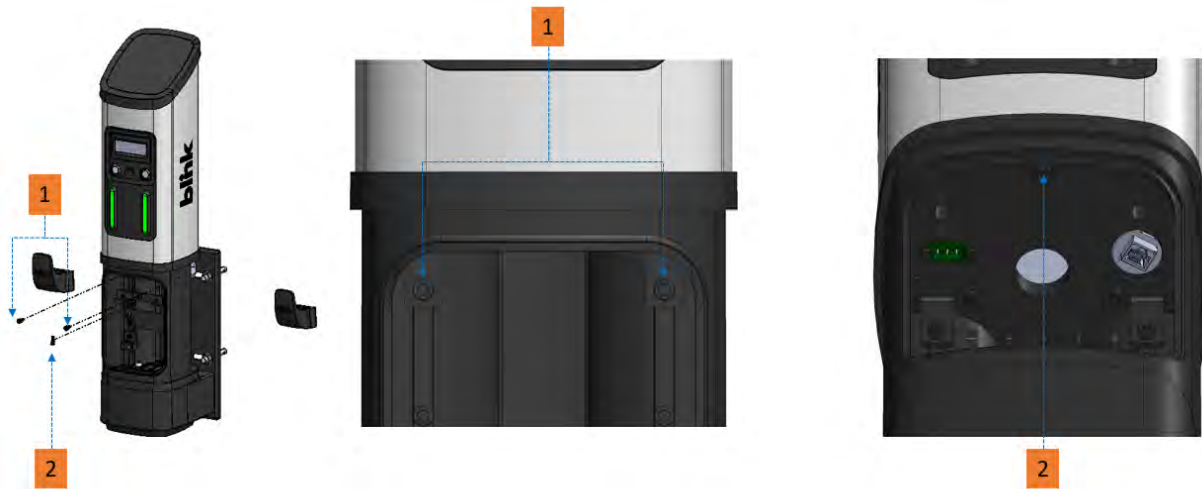

Fig. 34 – Head unit mounting screw locations

## ⚠ CAUTION

- Refer to General Requirements section for station weights.
- Remove the 2x rubber covers and M6x12mm T30 Tamper-Resistant Torx screws from the cable holstering area of the Access Panel using the provided driver bit
- Carefully place the charging station head unit on top of the wall mount bracket as shown in the illustration.
- Align the Guide poles in the wall mount bracket with the base of the head unit.
- Secure the Charging station Head Unit to the Pedestal Unit with the 3 mounting screws (Two from front M6x10mm [1] and one from bottom side M6x25mm [2]).
- Ensure that the charging station is plumb using a level. Check that the Head Unit is now securely fastened to the Pedestal.

### 5.3. CONNECTING INPUT WIRING

#### **⚠️ WARNING**

**VERIFY ALL CONDUCTORS ARE DE-ENERGIZED BEFORE PROCEEDING.**

**Refer to the wire color codes and strictly adhere to this convention while connecting the charging station and electrical supply wires. Incorrect wiring can lead to an electrical hazard.**

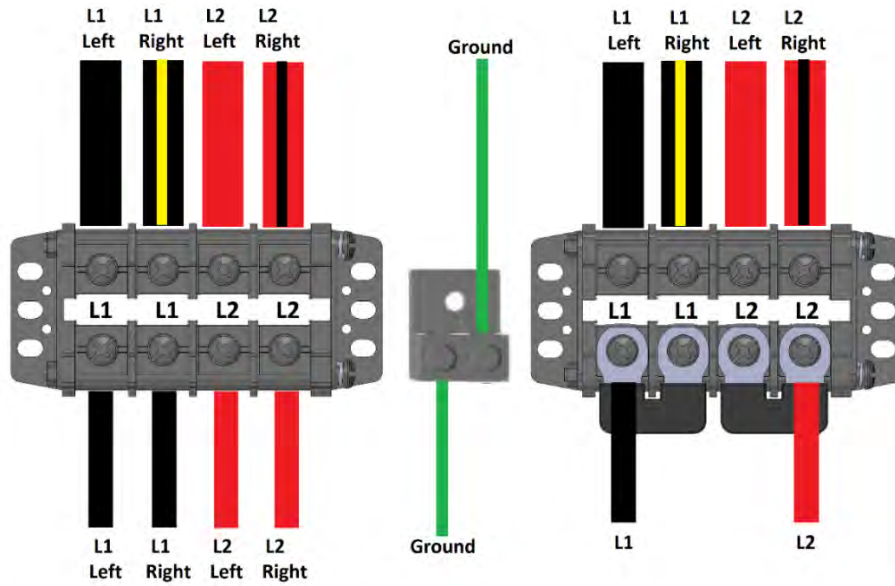

Dual Source Input Wiring

Single Source Input Wiring

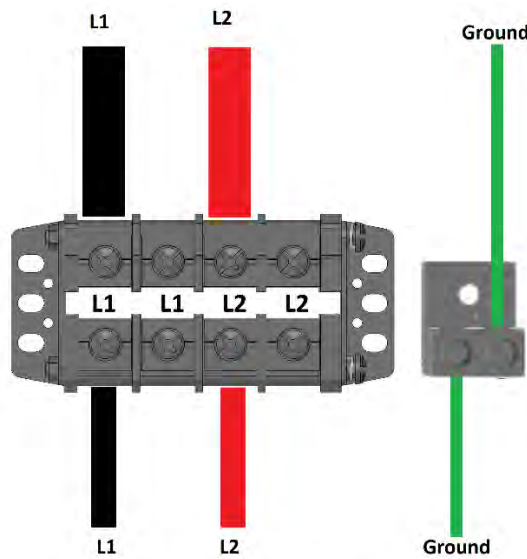

Single Port Input Wiring

Fig. 35 - AC input wire connections

- If necessary, open the Access Panel by removing the two T30 Tamper-Resistant Torx screws located in the charging cable holsters.
- Locate and access the charger input wires inside (Green = Ground, Black + Red = Left port circuit, Black/stripe + Red/stripe = Right port circuit). All but the Ground wire will have ring terminal connectors pre-installed.
- Connect the Green wire to the grounding lug at the lower left of the terminal block.
- Attach the 4 phase wires to the top side of the input terminal block in the configuration shown above (from left to right the color code should be Black, Black/stripe, Red, Red/stripe).
- Connect the Ground wire from the building side to the grounding lug at the lower left of the terminal block.
- Install ring terminal connectors (for M6 or 1/4" stud) on the building-side input wires for the Left and Right port circuits and connect them to the corresponding positions on the terminal block.
- **If the charger is connected to a single circuit breaker (single source/shared power configuration), the provided shorting jumpers must be installed on the input (bottom) side of the terminal block, to short-circuit L1 Left and Right together, and short-circuit L2 Left and Right together. AC input wires should be connected to only one of the L1 and L2 terminals.**
- Once all input wiring is connected, carefully push any slack back into the wiring cavity, and replace the access panel cover using the screws previously removed.

### 5.3.1. Holster Panel Assembly

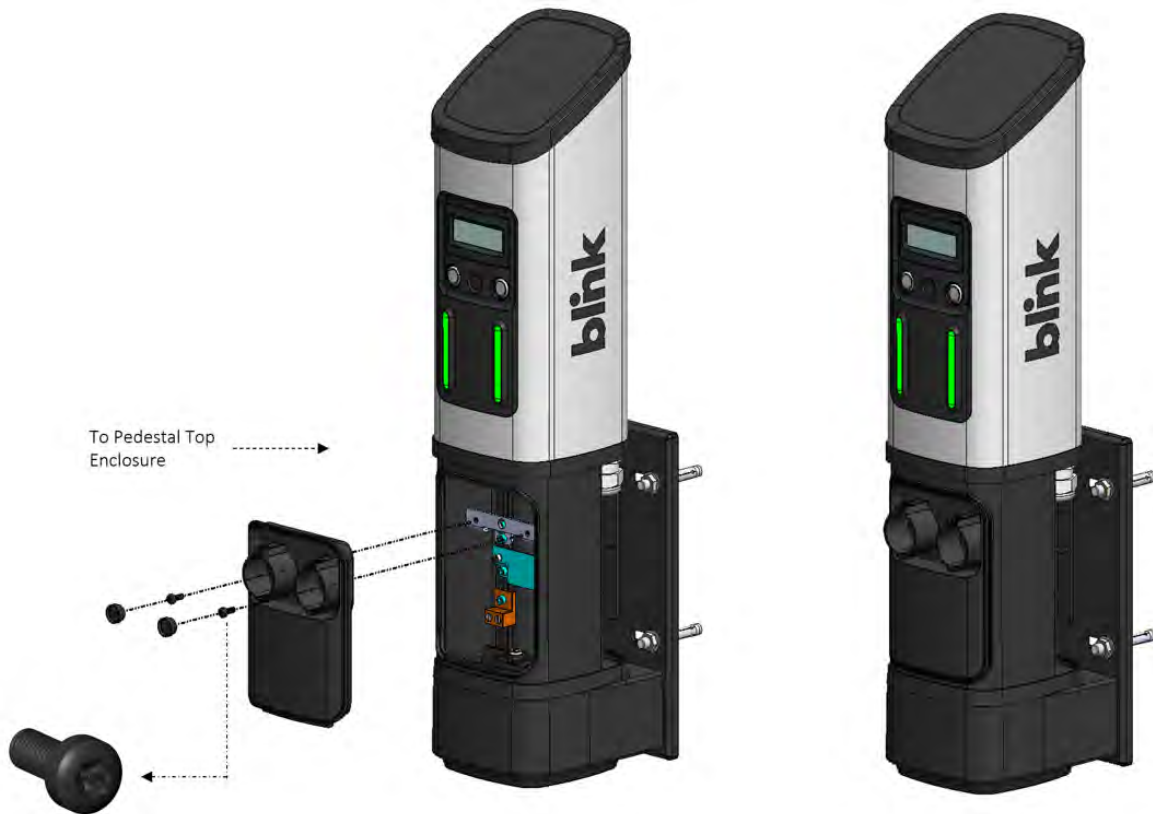

Fig. 36 – Holster panel assembly

- Once installation wiring is connected, re-install the wiring access panel using the 2x M6 x 12mm T30 Tamper-Resistant Torx screws which were previously removed.
- Re-install rubber caps over the screws to hide the screws
- Check that the holsters are secure and firmly attached to the Head Unit

## 5.4. DERATE SWITCH

The Derate Switch on the Series 7 and Series 8 ISO chargers can be used to decrease the maximum AC current offered by the charger. If a modified output configuration is required (based on Tables 1 and 2 in the Electrical Requirements section), follow these steps to derate the charger's output accordingly.

- **NOTICE** The Derate Switch must **ONLY** be adjusted by installers or Blink qualified service personnel.
- **NOTICE** When a dual-port charger is wired to a **SINGLE** source (both sides connected to a single circuit breaker), **Load Management** must be set up on the Blink Network to properly limit the charger output. To set up Load Management, call Blink Customer Service before or after installing the charger.
- **NOTICE** Failure to set up Load Management in a Single Source configuration may result in tripping of circuit breakers or other protection devices, or damage to equipment.

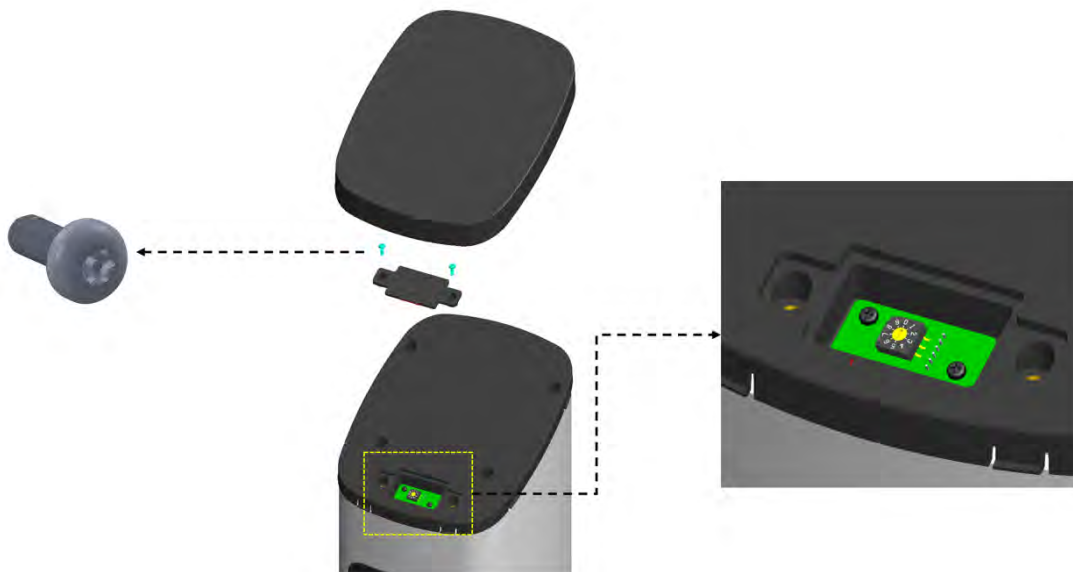

Fig. 37 - Derate switch location

- To access the derate switch, first remove the charger's Top Outer Cover (snap-fit) using a plastic wedge or other non-scratching tool.
- Use the provided T10 Tamper-Resistant Torx bit to remove the two screws for the Derate Switch Access Panel.
- Using a small plastic screwdriver, set the derate switch to the appropriate Derated Value from Table 3 below.
- When finished, re-install the Derate Switch Access Panel to the Top Inner Cover
- Check that the Derate Switch Access Panel is secure and is firmly attached to the Top Inner Cover

- Replace the Top Outer Cover

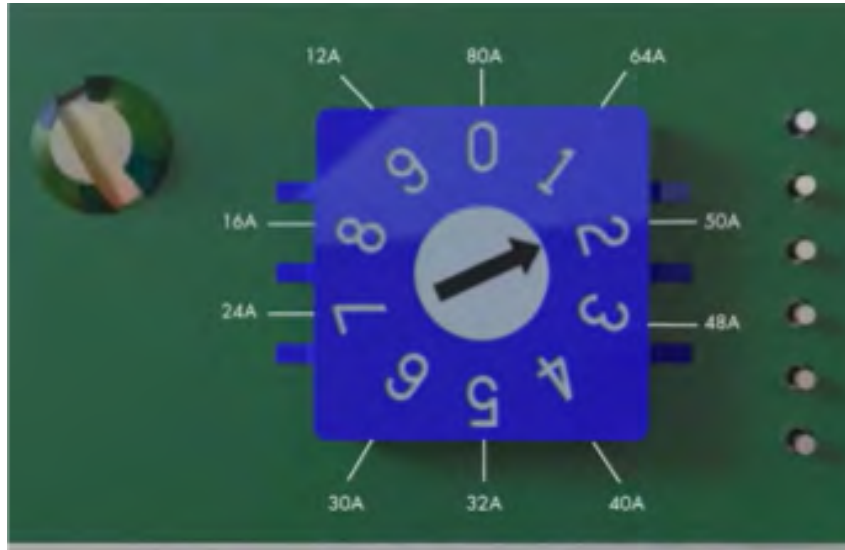

Fig. 38 – Derate switch settings

<b>Switch Position</b>	<b>Derated Value</b>
<b>0</b>	80A
<b>1</b>	64A
<b>2</b>	50A
<b>3</b>	48A
<b>4</b>	40A
<b>5</b>	32A
<b>6</b>	30A
<b>7</b>	24A
<b>8</b>	16A
<b>9</b>	12A

Table 7 – Derate switch settings

## 6. CABLE MANAGEMENT SYSTEM (CMS) - PACKAGE CONTENTS

### 6.1. PEDESTAL MOUNT CABLE MANAGEMENT SYSTEM

CMS Pedestal Head Unit (Dual)



CMS Pedestal Base Unit



CMS Drilling Template





M12 Concrete Anchors - Qty 3

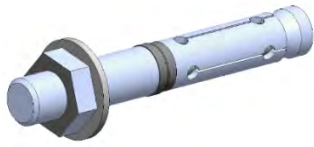

CMS Pedestal Screws (M10x65mm Tamper-Resistant Torx) - Qty 3

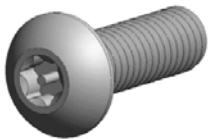

Pedestal Mounting Screws (M8x16mm) - Qty 2

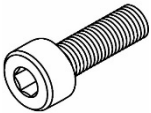

CMS Cable Clamp Screws (M3 x10mm) - Qty 4

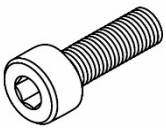

CMS Cable Cap Screws (M4 x25mm Tamper-Resistant Torx) - Qty 4



CMS Cable clamp



CMS Cable Bottom Cap



**6.2. WALL MOUNT CABLE MANAGEMENT SYSTEM**

CMS Wall Mount Bracket

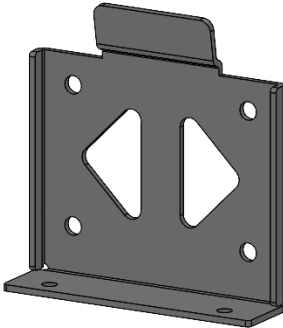

CMS Wall Mount Head Unit (Single)



Anchor Bolts 1/2"/M12 - Qty 4

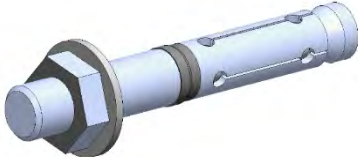

CMS Cable Clamp Screw (M3 x10mm) - Qty 4 (dual)/Qty 2 (single)

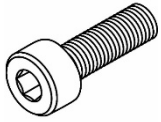

CMS Cable Cap Screw (M4 x 25mm Tamper-Resistant Torx) - Qty 4



CMS Wall Mount Head Unit Mounting Screws (M6 x16mm Tamper-Resistant Torx) - Qty 2



CMS Cable clamp



CMS Cable Bottom CAP



## 7. CABLE MANAGEMENT SYSTEM (CMS) INSTALLATION

### 7.1. SERIES 7/SERIES 8 ISO CHARGER WITH CABLE MANAGEMENT SYSTEM - PEDESTAL INSTALLATION

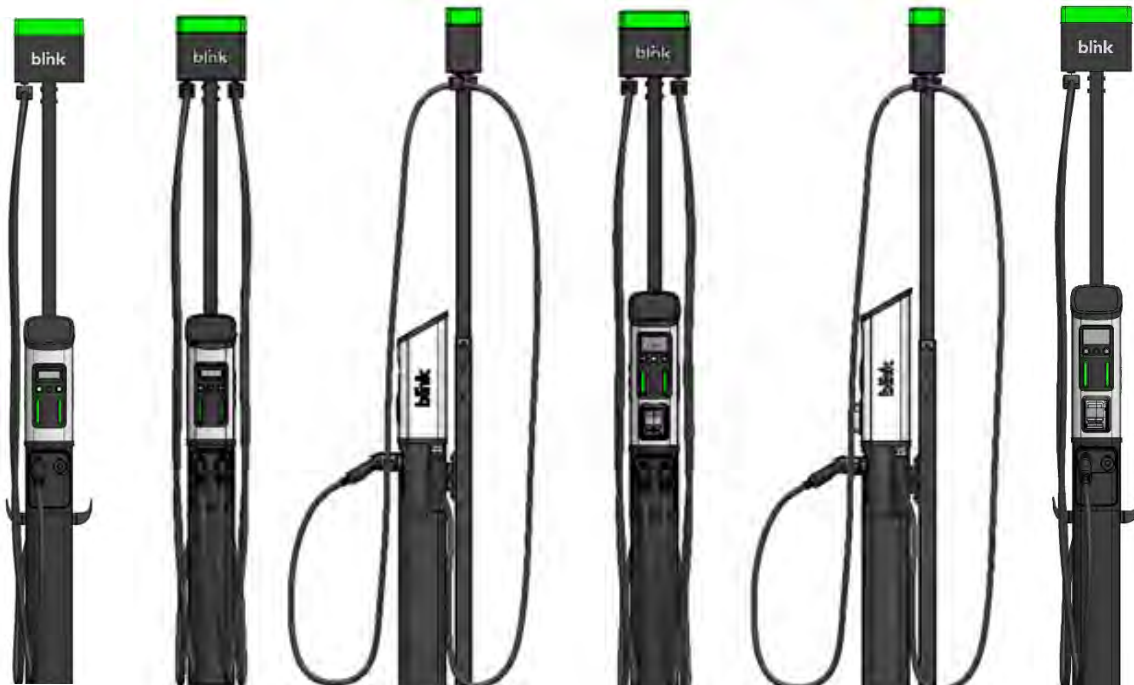

Fig. 39 – Series 7 and Series 8 ISO cable management system with pedestal

#### 7.1.1. Site Location

Select the location for the charging station. To mount the charging station, first prepare a concrete pad properly aligned to the parking space. The concrete pad should be positioned such that the distance between the charging station and electric vehicle is enough to minimize the likelihood of damage.

### 7.1.2. Cable Management System Drilling Template Installation

#### **⚠ WARNING**

**VERIFY ALL CONDUCTORS ARE DE-ENERGIZED**

Note: If installing a new concrete pad, the CMS drilling template must be installed at the same time as the Pedestal drilling template.

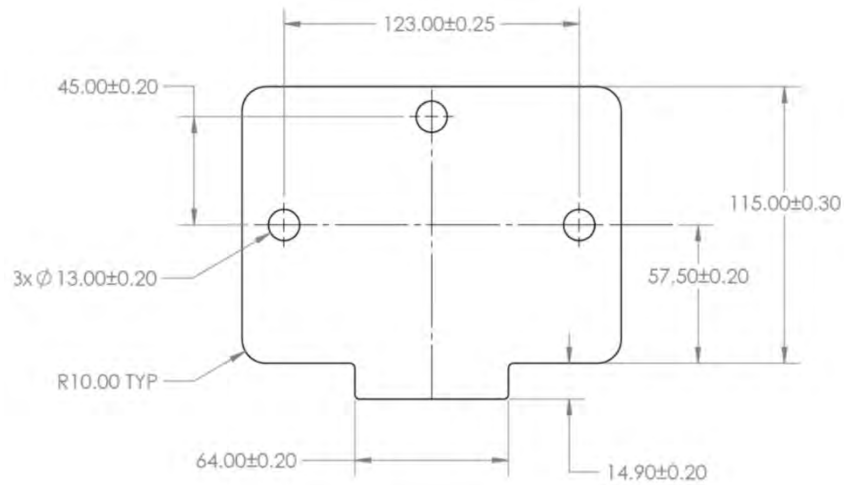

Fig. 40 – Cable management system drilling template dimensions

- Ensure the CMS drilling template is oriented properly with respect to the pedestal drilling template
- Install the CMS drilling template using the provided concrete anchors.
- Drilling template surface should be in level with the ground.

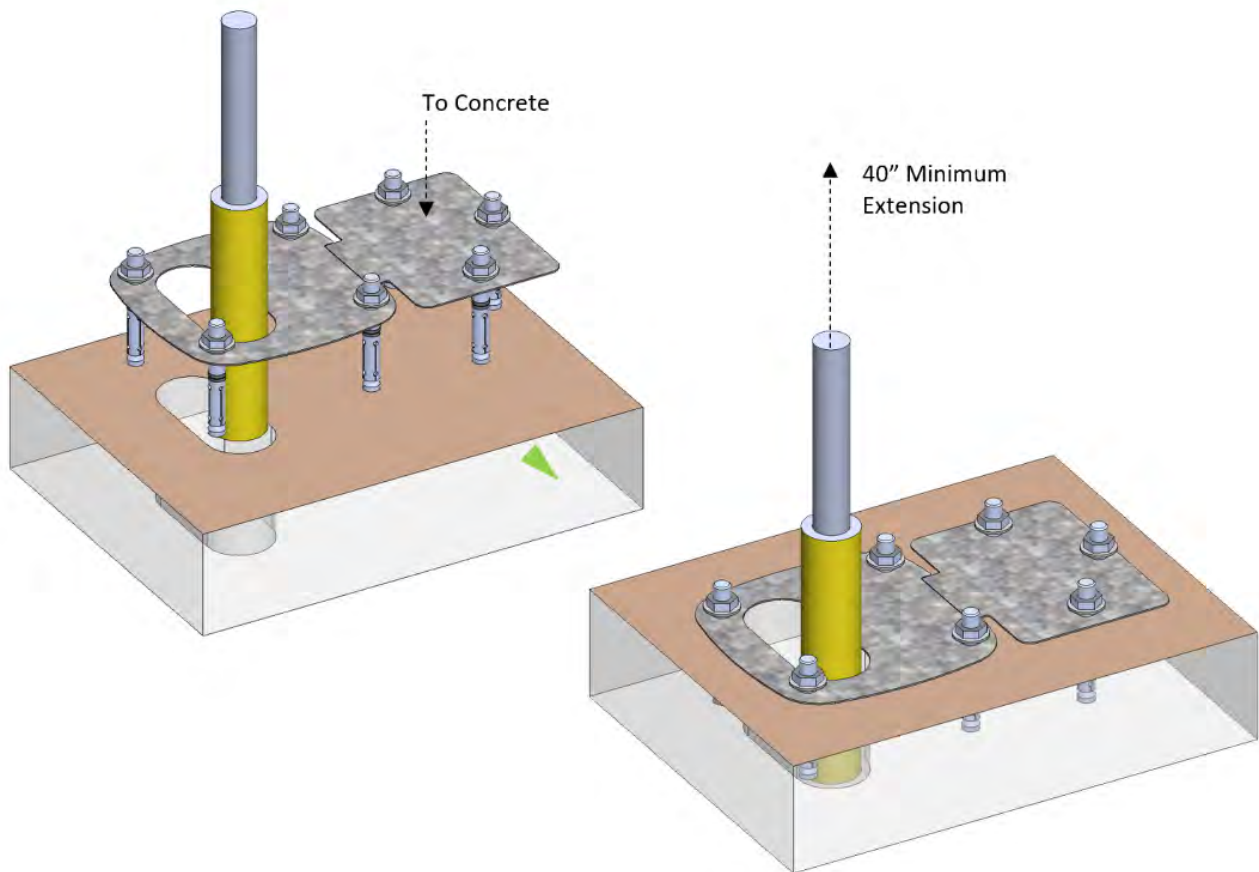

Fig. 41 - Drilling template installation

### 7.1.3. Cable Management System Pedestal Installation

#### Install CMS Pedestal Base Unit:

- Remove nuts and washers from anchor bolts
- Place the CMS pedestal base on the template such that the bolt holes are aligned.
- Re-install nuts and washers, but do not tighten fully.
- Locate the (4) leveling screws on the pedestal base assembly. Adjust leveling screws to make Pedestal Base plumb (check with Level at two points separated by 90 degrees).
- Gradually tighten anchor bolts to secure the Pedestal Base. Re-check for plumb.

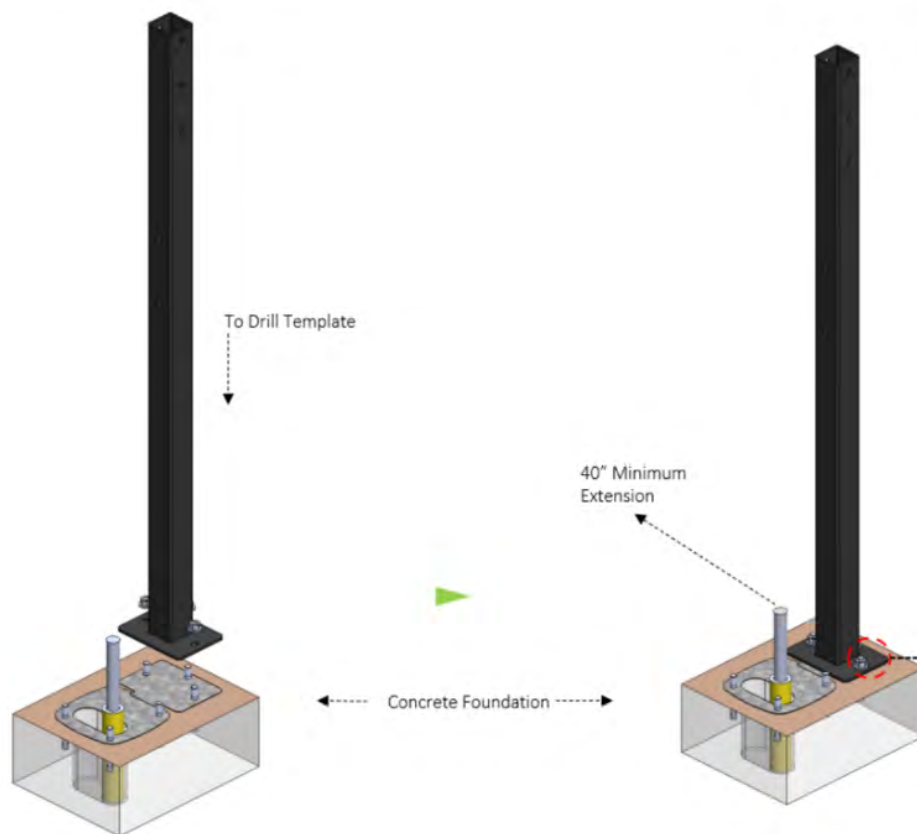

Fig. 42 – Installing Cable Management System pedestal base



Fig. 43 - Checking pedestal base for level

### Cable Management System Pedestal Head Unit Installation

- Carefully place the CMS Pedestal Head Unit on top of the CMS Pedestal Base as shown in the illustration.
- Align the Guide poles in the CMS Pedestal Head Unit with the CMS pedestal.
- Use stopper screw for aligning CMS Pedestal Head Unit to CMS Pedestal Base.
- Secure CMS Pedestal Head Unit to the CMS Pedestal Base with (3) M10x60mm mounting screws.
- Ensure the CMS Pedestal Head Unit is plumb using a level. Check that the CMS Pedestal Head Unit is now securely fastened to the CMS Pedestal Base.

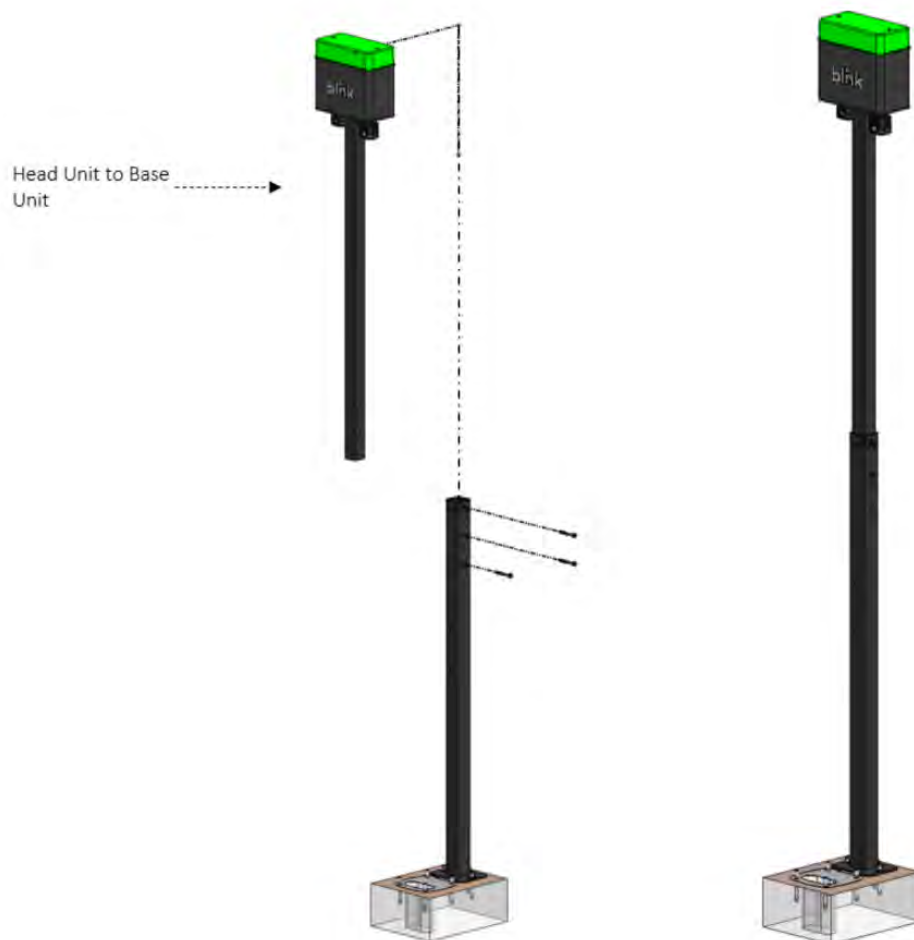

Fig. 44 - CMS Pedestal Head Unit installation

### Connecting Charger to CMS Universal Assembly

- Secure Series 7 or Series 8 ISO Pedestal to the CMS Universal Assembly Unit with (2) M8x16mm mounting screws
- Ensure the pedestal is securely and firmly fitted into CMS Universal Assembly

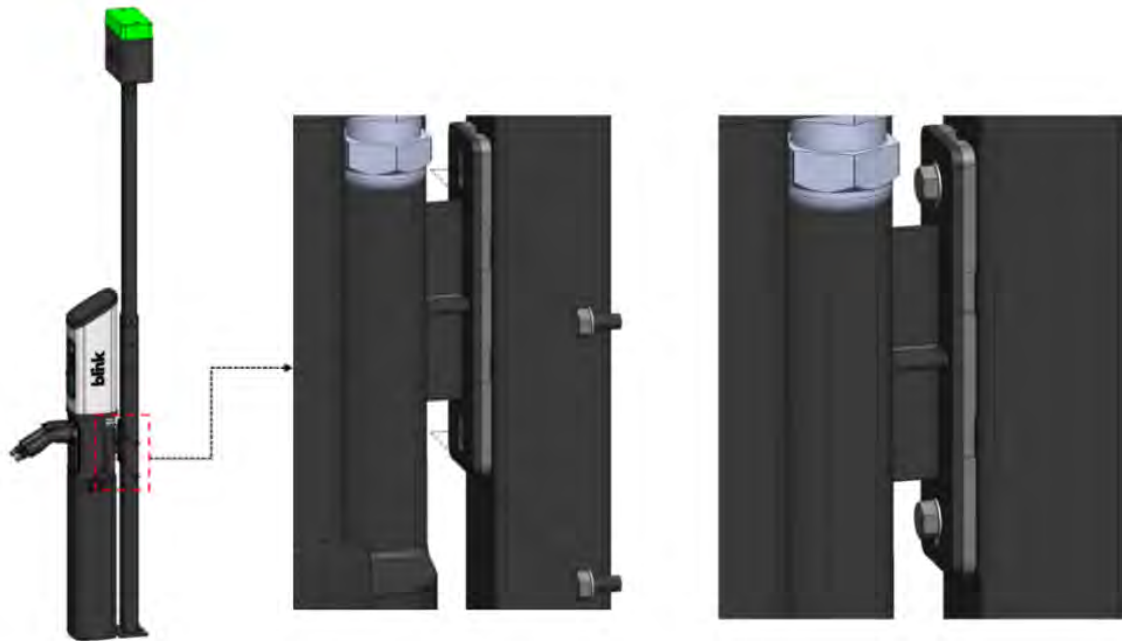

Fig. 45 – Connecting charger pedestal to CMS

#### 7.1.4. CMS Cable Clamp Installation

- Put both sides of the CMS Cable Clamp at approximately the midpoint of the charging cable.
- Use (4) M3 x 10mm to assemble the CMS Cable Clamp to the charging cable.



Fig. 46 – Installing CMS cable clamp

- Use (2) M4 x 25mm Tamper-Resistant Torx screws to assemble the CMS Cable Bottom Cap to CMS Cable Top Cap



Fig. 47 – Installing CMS cable bottom and top cap

## 7.2. SERIES 7/SERIES 8 ISO CHARGER WITH CABLE MANAGEMENT SYSTEM – WALL MOUNT INSTALLATION

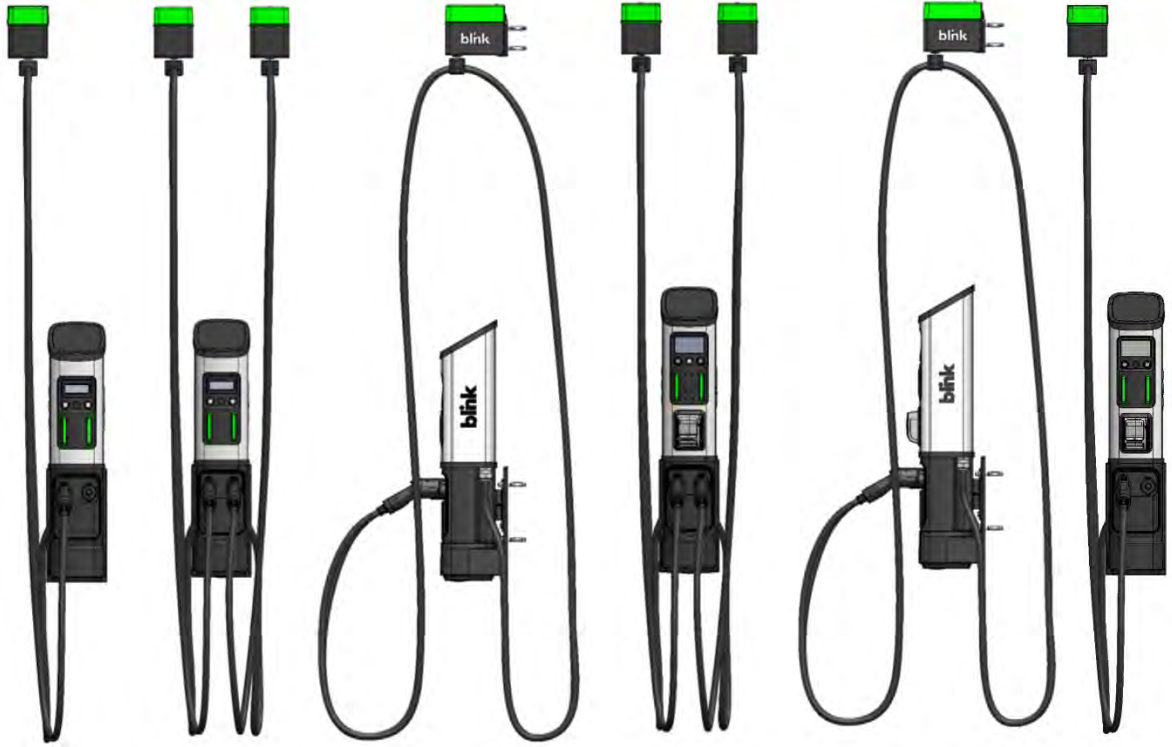

Fig. 48 – Series 7 and Series 8 ISO cable management system with wall mount

### 7.2.1. Site Selection

The charging station should be positioned such that the distance between the charging station and electric vehicle is sufficient to minimize the likelihood of damage (suggested min. 3 ft). Two alternatives are illustrated below:

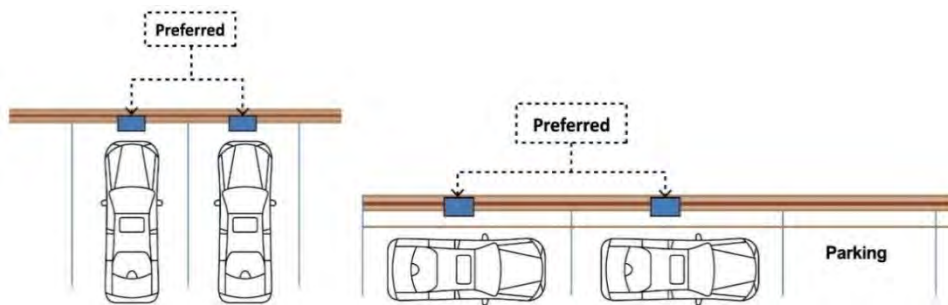

Fig. 49 – Site location recommendations

### 7.2.2. Preparing the Wall

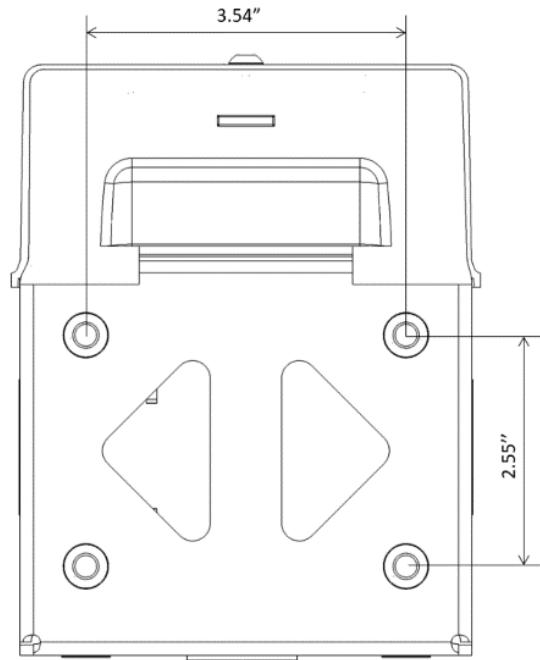

Fig. 50 – Cable management system wall mount bracket template

At the selected location, place the wall mount bracket on the wall such that the top of the bracket is at a height of 91.5 inches (Check local codes).

- If the wall is made of solid concrete or brick, use anchor bolts to secure the wall-mount to the wall. For walls other than concrete, use fasteners appropriate for the material.

### 7.2.3. CMS Wall Mount Bracket Installation

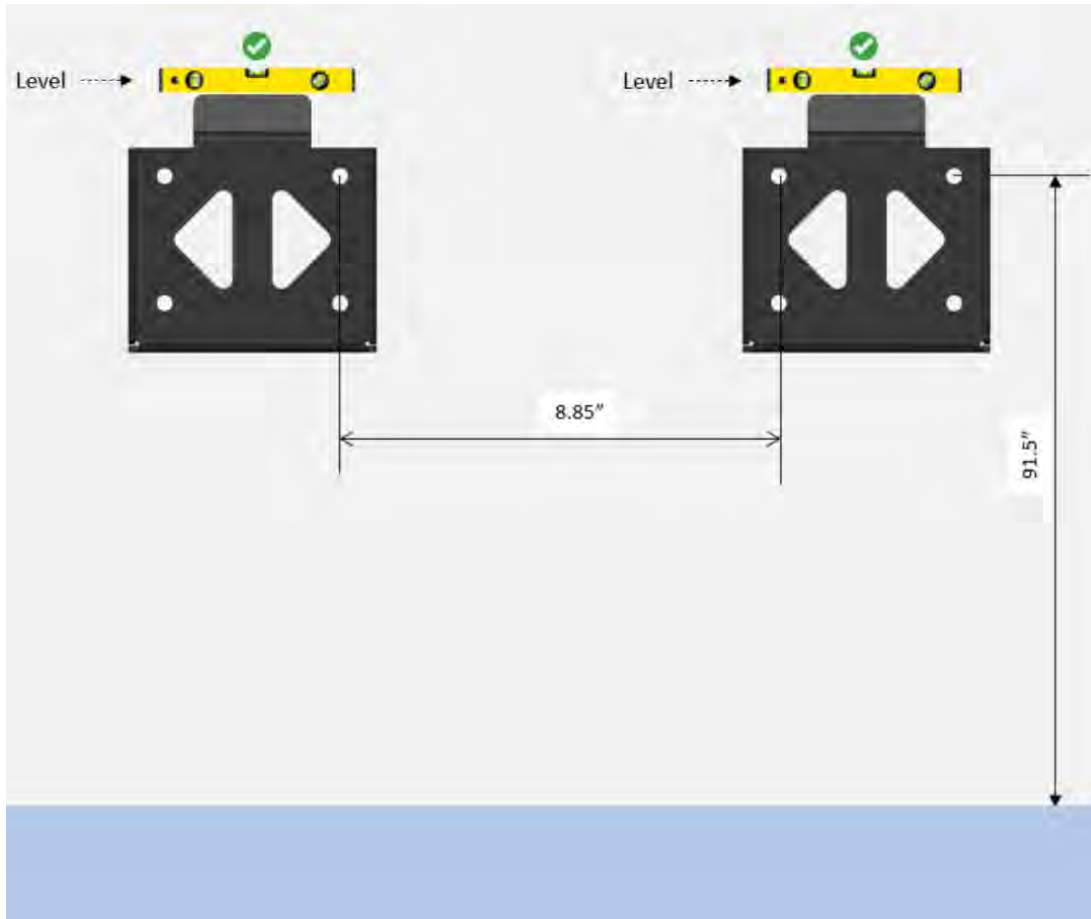

Fig. 51 - CMS wall mount dimensions

- Now secure the wall-mount with the bolts (if concrete or brick wall), or with appropriate fasteners (for other material).

#### 7.2.4. CMS Wall Mount Head Unit Installation

Refer to General Requirements section for station weights.

- Carefully place the CMS Wall Mount Head Unit on top of the CMS Wall Mount Bracket as shown in the illustration.
- Align the CMS Wall Mount Head Unit with the CMS Wall Mount Bracket.
- Secure CMS Wall Mount Head Unit to the Wall Mount Bracket with (2) M6 x16mm Tamper-Resistant Torx screws (from bottom side).

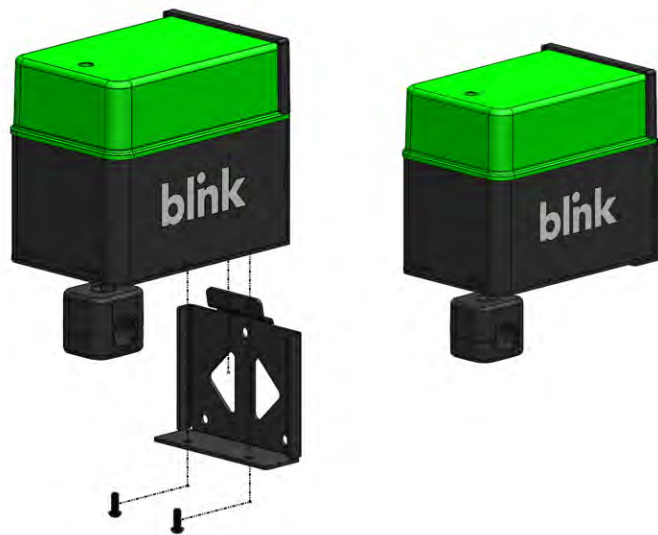

Fig. 52 – CMS wall mount head unit installation



### 7.2.5. CMS Cable Clamp Installation

- Put both sides of the CMS Cable Clamp at approximately the midpoint of the charging cable.
- Use (4) M3 x 10mm to assemble the CMS Cable Clamp to the charging cable.



Fig. 53 – Installing CMS cable clamp

- Use (2) M4 x 25mm Tamper-Resistant Torx screws to assemble the CMS Cable Bottom Cap to CMS Cable Top Cap

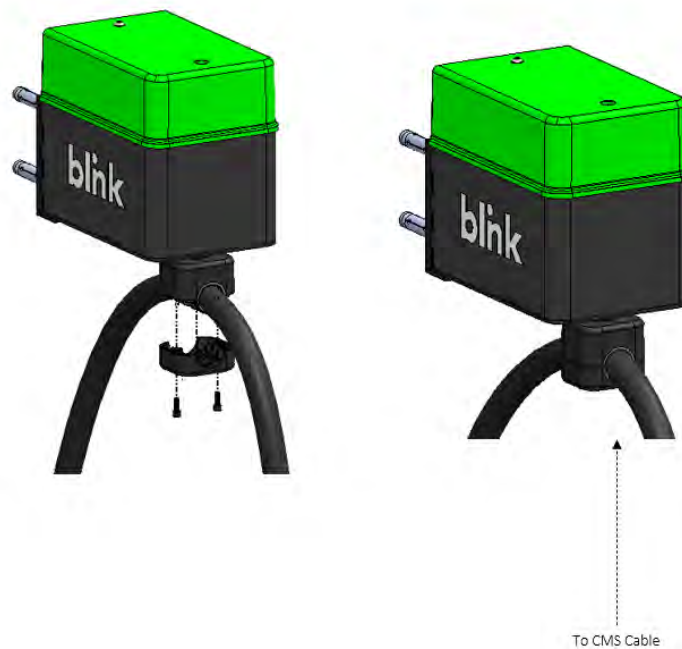

Fig. 54 – Installing CMS cable bottom and top caps



## 8. COMMISSIONING AND ENERGIZATION

### 8.1. STATION COMMISSIONING

After the stations have been installed and prior to energization, **please contact Customer Service at 480-405-2346 (between 7:00 AM and 8:00 PM EST) or [Onboarding@Blinkcharging.com](mailto:Onboarding@Blinkcharging.com) to complete station enrollment. If calling outside those hours, please leave a detailed message. Please have the station serial number(s) ready with you (located on left hand side of the stations).**

If modified output configurations are needed (per the guidelines in the Electrical Requirements section), please provide the following information for each station:

- Panel voltage: **(Example - 120/208V or 120/240V)**
- Circuit numbers & amperage feeding the charging stations: **(Example – CKT 37/39 2 Pole 60A)**
- Serial Numbers connected to each circuit number: **(Example: BAE\*\*\*\*\* Circuit 37/39)**

If Load Management is needed (when using a single source input to a dual-port charger), please provide the following information for each station:

- Panel(s) name: **(Example – PNL1B)**
- Panel(s) voltage & amperage: **(Example - 120/208V 225A)**
- Circuit numbers & amperage feeding the charging stations: **(Example – CKT 37/39 2 Pole 100A)**
- Serial Numbers connected to each circuit number: **(Example: BAE\*\*\*\*\* Circuit 37/39)**

### 8.2. INITIAL POWER-UP SEQUENCE

**▲ CAUTION** Be Aware of High Voltage!

After installation, station registration, and load management and/or modified output configurations have been completed (if applicable) the Blink station is ready to be energized.

1. Verify AC source breaker and any AC source isolation disconnects are OFF and locked out.
2. Verify charger is not powered on at input terminals.
3. Verify input connections (L1, L2, and Ground/PE) are properly terminated and secure.
4. Check for any damage to the charger enclosure and mounting devices.
5. Verify there are no short circuits after the AC source breaker or AC source isolation disconnect by measuring the resistance on charger's AC input terminals.
  - a. between phases should be  $> 0.5M\Omega$
  - b. between phases and ground should be infinite
6. Verify all AC source equipment covers are installed and equipment is closed securely.
7. Remove Lockout equipment from AC source breaker or AC source isolation disconnect.

8. Energize charger at source breaker or isolation disconnect.
9. Verify AC voltage is 208/240 from each respective L1 (left and right) to each respective L2 (left and right).
10. Verify AC voltage is 120 from each phase conductor to Ground/PE.
11. Close wiring access panel.

## 9. OPERATING INSTRUCTIONS

Read all the instructions before operating this product.

### 9.1. OPERATING PRECAUTIONS

- **⚠ WARNING** Please make sure that the unit is properly commissioned in accordance with the commissioning instructions before it is used.
- **⚠ WARNING** Do not use this product if the enclosure or charging connector are broken or open or if it is damaged or been tampered with.
- **⚠ WARNING** Do not use the charger if there is water intruding into the charger.
- **⚠ WARNING** Do not use this product if the power cable or charging cable have any damage.
- **⚠ WARNING** Do not put any tool, material, finger or other body part into the charging connector or EV connector.
- **⚠ CAUTION** The product should be inspected by a qualified installer prior to initial use. Under no circumstances will compliance with the information in this manual relieve the user of his /her responsibilities to comply with all applicable codes and safety standards.

## 9.2. OPERATING INSTRUCTIONS

### 9.2.1. Initialization and Idle State

When the charger is powered on, it shows an initialization screen for around 2 minutes:

- Series 7 chargers show “Starting Up...” on the LCD display
- Series 8 chargers show the Blink logo on their LCD display

Once the system is initialized, the screen will cycle through the idle display sequence:

- Series 7 ISO:

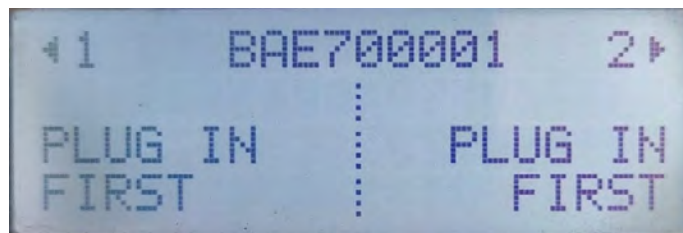
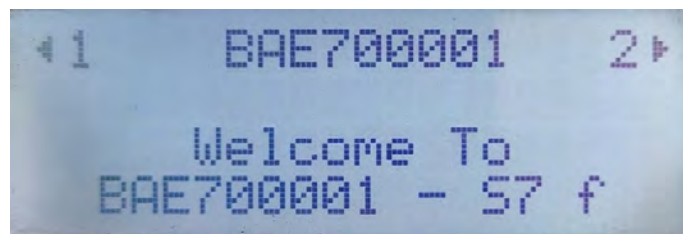

Fig. 55 - Series 7 ISO Idle display (dual-port)

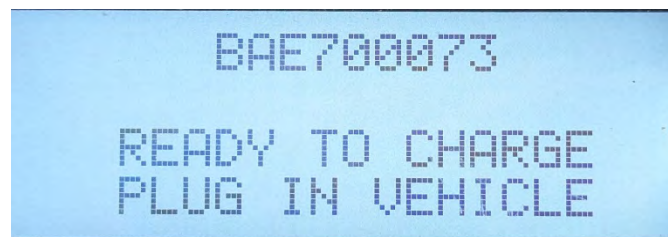

Fig. 56 - Series 7 ISO Idle display (single-port)

- Series 8 ISO:



Fig. 57 – Series 8 ISO Idle display

### 9.2.2. User Authorization

- Authorization can be done via RFID card, mobile app, mobile number, QR code (when using the Blink app) or credit card  
Note: Optional credit card reader is required to use credit card (Series 8 only)
- Authorization may be performed either before or after the vehicle is plugged in.
- If both ports are plugged in but neither port has been authorized, the first connected port will receive the authorization first.
- Note: the display will only update on the side whose charging port has been authorized.
- Series 7 ISO:

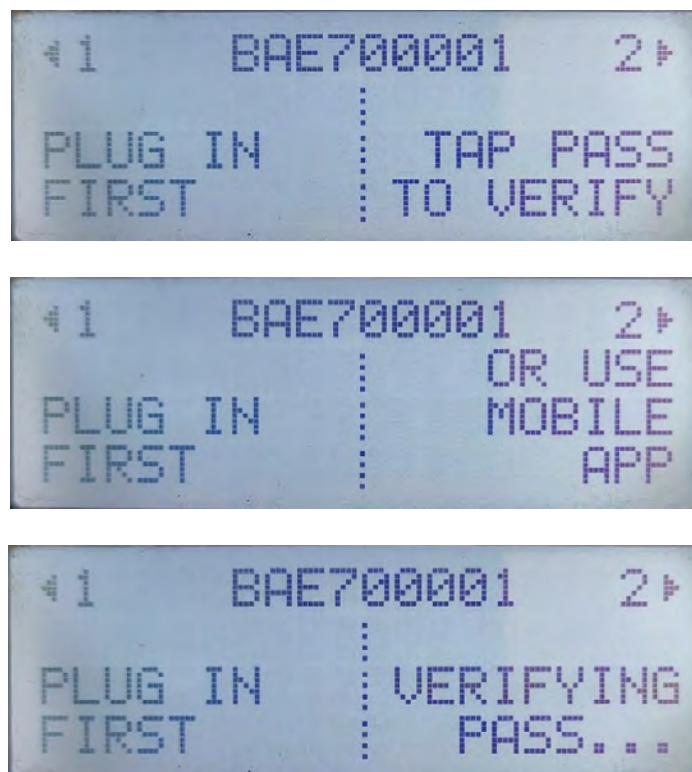

Fig. 58 – Series 7 ISO Authorization prompt (dual-port)

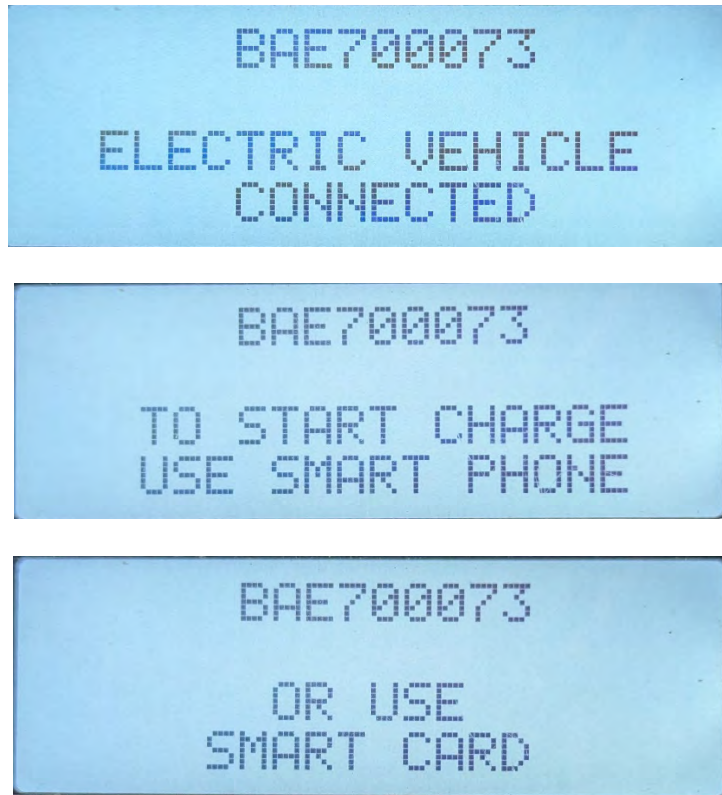

Fig. 59 - Series 7 ISO Authorization prompt (single-port)

- Series 8 ISO:



Fig. 60 – Series 8 ISO Authorization prompt

### 9.2.3. Charging

- Once the station has been authorized and plugged in, the display will show the charging screens.
- The charging screens display the current rate, time connected, kilowatt-hours consumed, and current wattage transfer rate.
- The display updates as the session continues.
- Series 7 ISO:

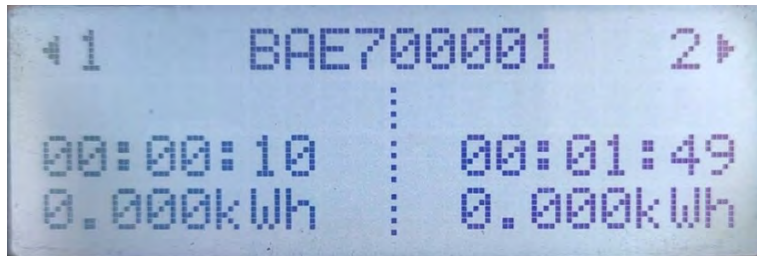

Fig. 61 - Series 7 ISO Charging display (dual-port)

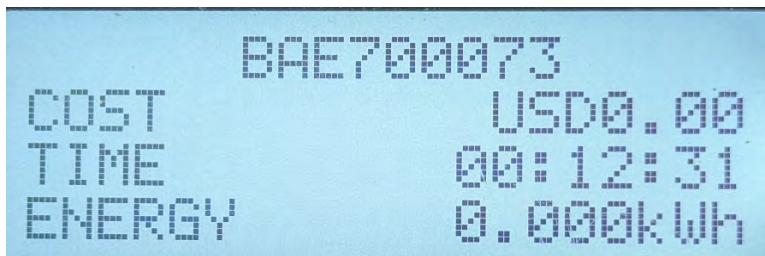

Fig. 62 - Series 7 ISO Charging display (single-port)

- Series 8 ISO:

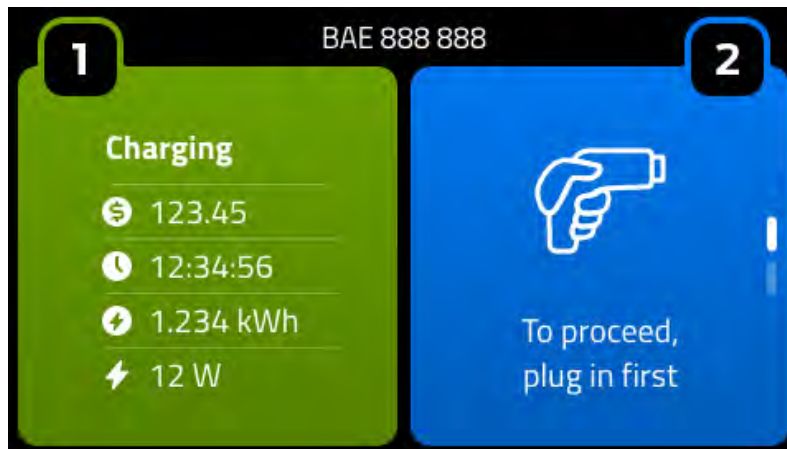

Fig. 63 – Series 8 ISO Charging display

### 9.2.4. Charging Complete

- Once the charging session is completed, the display shall update to show the total cost of the charging along with the current rate, total time, total kilowatt hours consumed and a thank you message will be visible on the charging complete page. The following illustrations demonstrate a charging complete status:
- Series 7 ISO:

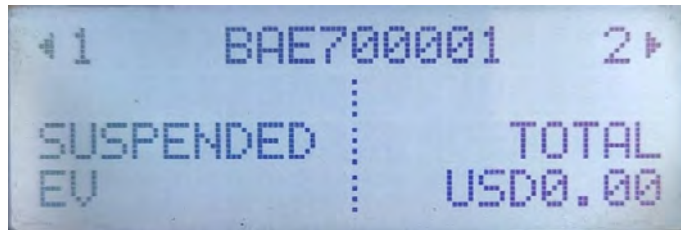

Fig. 64 – Series 7 ISO Charging Complete display (dual-port)

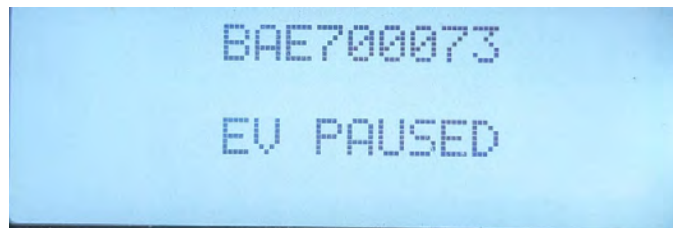

Fig. 65 – Series 7 ISO Charging Complete display (single-port)

- Series 8 ISO:

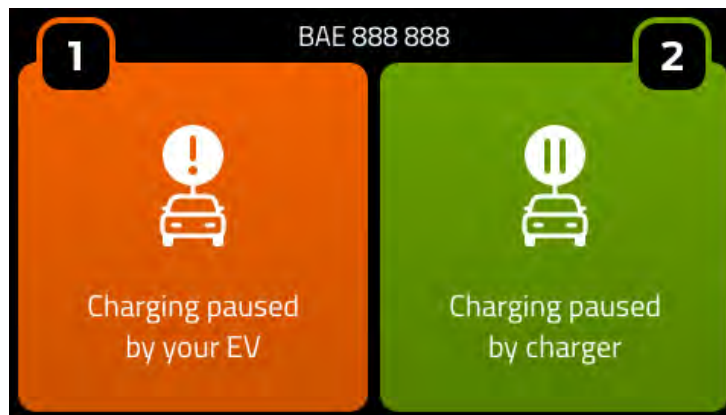

Fig. 66 – Series 8 ISO Charging Complete display

**NOTICE** Please make sure the charging connector is returned to the holder of the charging connector after charging to prevent damage.

### 9.3. OPERATING STATUS

The following table provides the LED indicator and the corresponding status

Status	LED Indicator	Description
Standby	Solid Green	The station is in a standby state
Authenticating	Breathing Aqua	The station is authorizing the charging session
Charging	Blinking Blue	During a charging session
Charge Complete	Solid Blue	The vehicle has stopped charging
Fault	Solid Red	Whenever an error is encountered

Table 8 - Operating Status LED Colors

### 9.4. CUSTOMER SUPPORT

Please contact customer support

- If the enclosure or screen is broken, cracked, opened, or shows any other indication of damage.
- If there is damage to the charging connector, charging cable or holder of the charging connector
- If there is water intruding into the charger, please cut off the power source immediately and contact Blink customer success team for repair.

Please record the status code number (if any) on the LCD monitor before calling customer support.

Contact information for Blink customer support:

**Customer Support: 888-998-2546 or [customerservice@blinkcharging.com](mailto:customerservice@blinkcharging.com)**

## 10. TROUBLESHOOTING

After energizing the station, both at-a-glance LED lights should illuminate BLUE. If both station at-a-glance LED lights do not illuminate BLUE, please refer to the following troubleshooting guidance:

- No LED lights or LCD screen: Voltage not present. Verify proper wiring, voltage, and circuit breaker(s) status
- Both LED lights RED, LCD screen displays, "Registration Required": Station registration needs to be completed
- Both LED lights RED, LCD screen displays, "GF 0800": Grounding problem. Check/verify solidly grounded electrical system integrity
- One LED light RED, one LED light BLUE, LCD screen displays, "GF 0100" or "GF0900": Voltage is not present to side of station illuminated RED. Verify proper wiring, voltage, and circuit breaker(s) status
- Both LED lights PURPLE, LCD screen displays, "Station Offline, Limited Access": Station not

communicating with Blink Network platform due to inadequate cellular signal

The Following table provides the list of commonly used error message codes displayed on the charger.

Error Message or Code	Description
Communication module or link connection fault	SLAC error, applicable only for chargers with PLC board
GF 0001	GFCI_FLAG_TRIP_EVENT
GF 0002	GFCI_FLAG_GROUND_TEST_FAIL
GF 0004	GFCI_FLAG_TRIP_EVENT_ON_CLOSURE
GF 0008	GFCI_FLAG_TRIP_EVENT_MAX_COUNT_EXCEEDED
GF 0010	GFCI_FLAG_RELAY_CLOSE_FAIL
GF 0020	GFCI_FLAG_LOAD_FAIL
GF 0040	GFCI_FLAG_RELAY_OPEN_FAIL
GF 0080	GFCI_FLAG_WELDED
GF 0100	GFCI_FLAG_SUPPLY_FAIL
GF 0200	GFCI_FLAG_CLOSE_RELAY
GF 0400	GFCI_FLAG_RELAY_IS_CLOSED
GF 0800	GFCI_FLAG_GROUND_CONNECTION_FAIL
GF 1000	GFCI_FLAG_GROUND_TEST_COMPLETED
J(STATE) 01	J1772_ERROR_NONE
J(STATE) 02	J1772_ERROR_VENTILATION_NOT_AVAILABLE
J(STATE) 04	J1772_ERROR_STATE_E
J(STATE) 08	J1772_ERROR_STATE_F

J(STATE) 10	J1772_ERROR_STATE_INVALID
-------------	---------------------------

Table 9 – Charger error codes

Please contact Blink Customer Service at 888-998-2546 for any questions or issues not listed.

## 11. CLEANING AND MAINTENANCE

### **⚠️ WARNING**

Blink EV charging stations may be cleaned in accordance with the following guidance:

- Use clean, soft cloth along with mild detergent to wash the dirt off
- Pour water gently from the top and use a wet/dry cloth to clean all the sides
- **Do not use excessive water pressure**
- **Do not use strong detergents or any other chemicals (acids, petrol, thinner, or any other solvent)**
- **Avoid exerting excessive pressure on the device while cleaning**
- **Do not open the device**
- **Do not use a vacuum cleaner**

## 12. WARRANTY

The Limited Product Warranty (“The Warranty”) applies to the Blink Series 7 ISO and Series 8 ISO chargers (stations) purchased from Blink or one of Blink’s authorized distributors or resellers. The Warranty shall cover the station from any manufacturer and/or workmanship defects for the period specified at the time of purchase. Upon verification of a valid warranty claim, Blink shall repair the station.

The following instances and events are not covered under the warranty policy (exclusions):

- Damage due to factors out of supplier’s control such as power surges, lightning, earthquake (i.e., “Acts of God”), etc.
- Damage due to negligence, failure to maintain the product, or any other event beyond Blink Charging’s reasonable control
- Alteration and/or modification to the product without prior approval from with Blink Charging
- Use of software, interfaces or parts not approved by Blink Charging
- Any damage to the EV charging cord unless it is the result of manufacturing defects in the cord or connector assembly
- Acts of vandalism
- Abuse, physical damage, misapplication, or damages due to station usage not outlined in official Blink documentation
- Installation or relocation of the station unless performed by a certified electrician or Blink approved technician

- Improper site preparation or maintenance
- Consumables such as RFID card, cable, internal wires and connectors

For additional information about the warranty policy, please refer to the official Blink Limited Warranty documentation or contact a Blink representative via the contact information provided in this document.