



Shown with optional cable management system

CoRe+ MAX™

The fastest¹ Level 2 charging station

Designed to evolve as more drivers make the switch to electric vehicles, the CoRe+ MAX™ is destined to become an integral part of your fleet, commercial, or workplace application.

Easy to use and reliable

- Cable management system (CMS) with unique counterweight system for smooth retraction.
- Built to last with rugged Type 3R aluminum water resistant enclosure and integrated cable holster for neat, safe cable storage.

Versatile and efficient

- Save on electricity costs with patented PowerSharing™ and PowerLimiting™ technologies.
- Customizable installation choices suit a variety of parking configurations.

Smart Station, Smarter Investment

- Monitor station health and gain key insights with the cloud-based management dashboard.
- Maximize uptime with proactive station monitoring and remote intervention services.



For Workplace

Offer EV charging services to your employees, with a solution that will evolve with you as more drivers make the switch to electric vehicles.



For Fleets

Ideal for fleet managers who wish to grow their light and medium duty EV fleets while maintaining affordable operational costs.

Available Configurations

DIMENSIONS

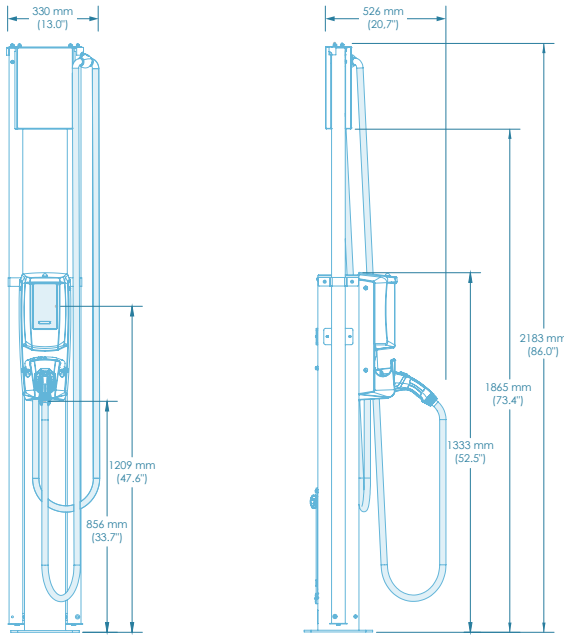

Single CoRe+ MAX™ on pedestal with CMS

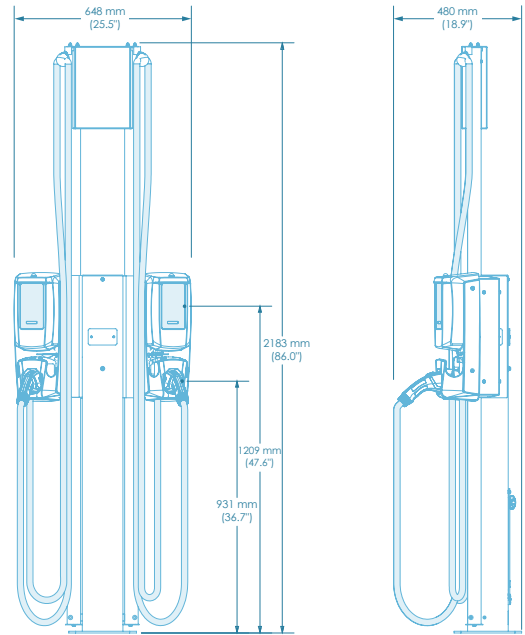

Dual side-by-side CoRe+ MAX™ on pedestal with CMS

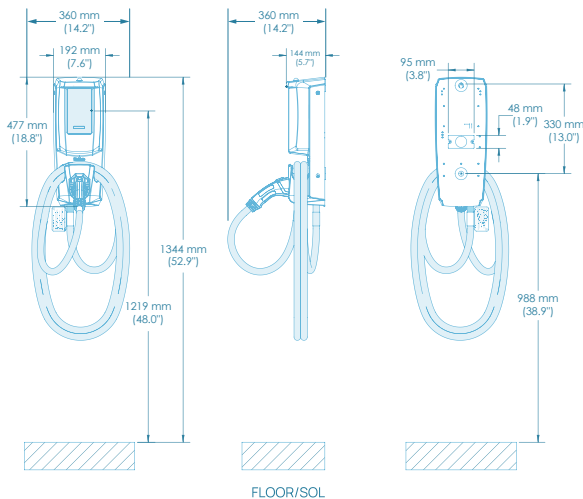

Wall Mount CoRe+ MAX™ (without CMS)

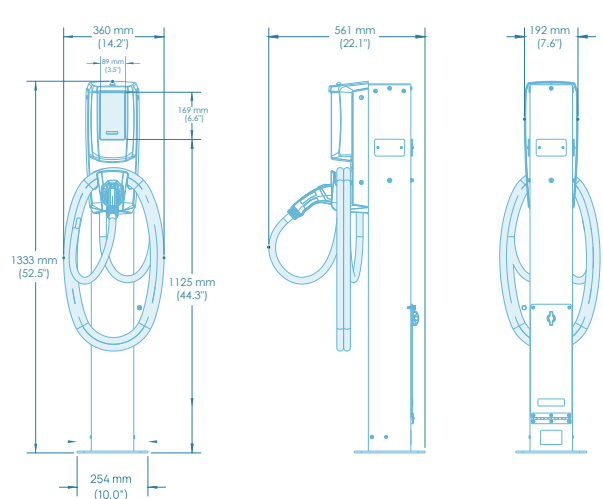

Single CoRe+ MAX™ on pedestal (without CMS)

Technical specifications

HARDWARE

Enclosure	Aluminum Type 3R
Charging Connectors	SAE J1772
Standard Cable Length	7.62 m / 25 ft
Cable Management System	Calibrated suspended weight (optional)
Cable Length with CMS	5.79 m / 19 ft
Operating Temperature	-40° C to 50° C / -40° F to 122° F
Humidity	Up to 95% (non-condensing)
Weight	Charging station: 9.5 kg / 21 lb Pedestal: 14.5 kg / 32 lb CMS (CoRe+ MAX): 10.9 kg / 24 lbs

ELECTRICAL

Input Rating	208 VAC or 240 VAC for each charging station
Max Output Power	1.2 kW to 19.2 kW 0.5 to 125 ADC
Max Output Current	6A to 80A
Installation Configurations	Pedestal or Wall-mount
Integrated Protection	GFCI, 20 mA, auto reset (3 attempts at 15-minute intervals)
Frequency	60 Hz

INTERFACE

Display	2 lines
RFID User Authentication	ISO 14443 A/B, ISO 15693

CONNECTIVITY

Communication Interface	ZigBee - IEEE 802.15.4 meshed network
Cellular Communication	Cellular - 4G/LTE (gateway installed separately)

CERTIFICATIONS AND COMPLIANCE

Certifications	CSA- C22.2 No. 280, UL 2594, CSA C22.2 No 281.1 and 281.2, UL 2231-1 and 2231-2, UL Listed
EMC Compliance	USA - FCC 47 CFR part 15 class A, CAN - ICES-003 (A)
ENERGY STAR	Yes
Metering Certifications	No
Accessibility	Yes

flo[®]

EV Charging
Done Right[™]

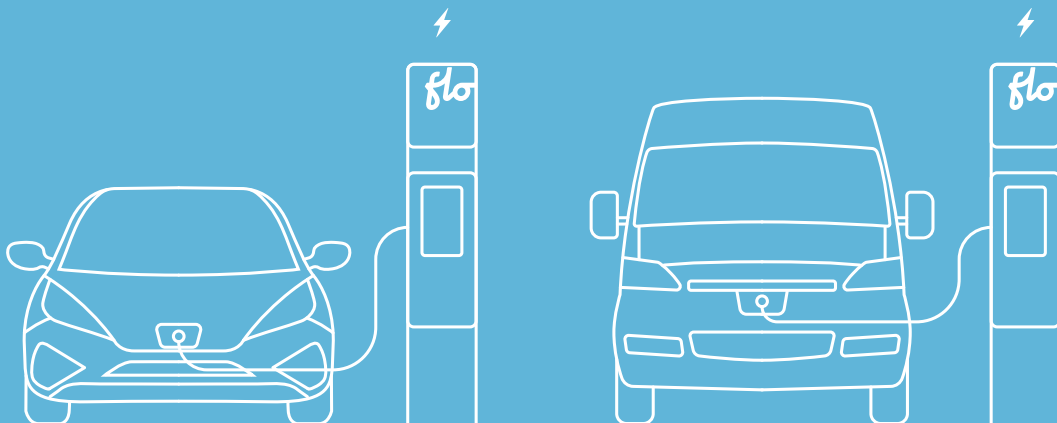

Made in North America