



**flo**®

# CoRe+™ Installation Guide

# IMPORTANT

Split Phase 120/240 VAC Supply or 3 phase 120/208 VAC (must be protected by a 40 A fuse or circuit breaker) Both lines must have 120V between ground.

Voltage supply must be grounded.

Require 2 lines and 1 ground connection. Neutral is not used. (Refer to Figure 1 and Figure 2)

Maximum output power: 7.2 kW @ 240 VAC or 6.3 KW @ 208 VAC

Built-in protection against overvoltage conditions and leakage current to ground

Connect the power supply of the EVSE with caliber 6 to 8 copper conductors

Any EVSE part alteration will automatically void the warranty.

Install the Communication Gateway prior to the Commissioning of the Station

The Communication Gateway is the property of AddÉnergie. Fees will be charged if the gateway is damaged or lost.

## IMPORTANT ELEMENTS TO CONSIDER WHEN INSTALLING THE COMMUNICATION GATEWAY:

- An outdoor installation is recommended. The Customer must provide a waterproof PVC box and install it less than 50 meters (164 ft.) from the stations.
- Never use a GFCI outlet to power the Communication Gateway.

Contact us when the Communication Gateway is installed to validate the signal levels

and activate Commissioning or for any other questions: **1 855 543 8356**

Fig. 1

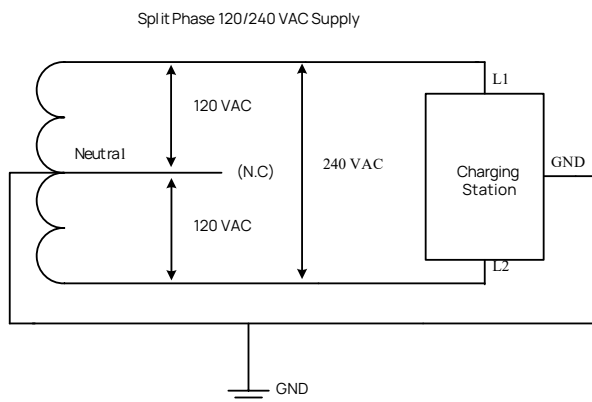
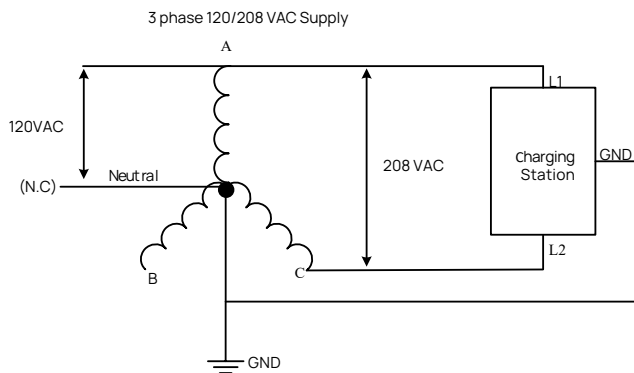

Fig. 2



# Table of Contents

Introduction .....	4
Statement .....	5
Installation and Safety.....	6
Dimensions .....	7
Wall or Post Mounting .....	8
Closing the Housing of the Station .....	11
Preliminary Tests and Commissioning .....	12
PowerSharing™ .....	13
Typical Installation .....	13
Installation for Cascading 40 A .....	14
Installation for Cascading 150 A.....	16
Copyright and Liability.....	16

# Introduction

## IC Canada

This device complies with Industry Canada licence-exempt RSS standard(s). Operation is subject to the following two conditions: (1) this device may not cause interference, and (2) this device must accept any interference, including interference that may cause undesired operation of the device.  
CAN ICES-3 (A) / NMB-3 (A)

## FCC Notice (for USA only)

This equipment has been tested and found to comply with the limits for a Class A digital device, pursuant to Part 15 of the FCC Rules. These limits are designed to provide reasonable protection against harmful interference when the equipment is operated in a commercial environment. This equipment generates, uses, and can radiate radio frequency energy and, if not installed and used in accordance with the instruction manual, may cause harmful interference to radio communications. Operation of this equipment in a residential area is likely to cause harmful interference in which case the user will be required to correct the interference at his own expense.

The enclosed device complies with Part 15 of the FCC Rules. Operation is subject to the following two conditions: (i.) this device may not cause harmful interference and (ii.) this device must accept any interference received, including interference that may cause undesired operation.

**Exposure to Radio Frequency Energy:** The radiated power output of the communication modules included in this device is below the limits recommended for the general population for uncontrolled exposure as defined in the FCC standards. This device should be operated with a minimum distance of at least 200 mm (7.87") between itself and a person's body and must not be colocated or operated with any other antenna in order to comply the conditions of the FCC Grants.

Modifications not expressly approved by FLO and AddÉnergie Technologies inc. could void the user's authority to operate the equipment.

# Specifications

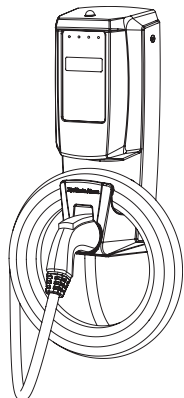

Models: **CoRe+V2, CoRe+VBV2, CoRe+PSV2**  
 Company Info: FLO (AddEnergie Technologies Inc.)



## Specifications:

Description of the available models:

- CoRe+V2: Level 2 charging station equipped with display and card reader
  - CoRe+VBV2: Level 2 charging station without display and without card reader
  - CoRe+PSV2: Level 2 charging station equipped with display, car reader and PowerSharing firmware
- Output connector: J-1772 compliant

Split phase 120/240 VAC supply or 3 phase 120/208 VAC (must be protected by a 40 A breaker or fuse) Maximum output current (power):

- CoRe+V2 and CoRe+VBV2: 30A (7.2 kW @ 240 V or 6.3 kW @ 208 V)
  - CoRe+PSV2: Dynamically controlled by a site controller between 8 A and 30 A (between 1.7 kW and 7.2 kW) Built-in protection against overvoltage conditions and leakage current to ground
- Operating temperature range: -40 °F to 122 °F (-40 °C to 50 °C)

4X enclosure type requirements, suitable for outdoor use.

- Shipping weight: Approximately 33lbs (14.97 kg)

Security standard compliance:

- CSA C22.2 No. 0-10 General Requirements – Canadian Electrical code, part II
- CSA 281.1-12/UL2231-1 Standard for safety for personnel protection systems for electrical vehicle (EV) supply circuits: General requirements
- CSA 281.2-12/UL2231-2 Standard for safety for personnel protection systems for electric vehicle (EV) supply circuits: Particular requirements for protection devices for use in charging systems
- CSA C22.2 No. 280-13/UL2594 (1<sup>st</sup> edition) Electric vehicle supply equipment (EVSE)
- Supported communication protocols: ONP and OCPP (CoRe+V2 and CoRe+PSV2 only)
- This product is approved by the California Type Evaluation Program
- The following models are certified ENERGY STAR® 1.2: CoRe+V2 and CoRe+PSV2 only

# Installation and Safety

## INSTRUCTIONS PERTAINING TO A RISK OF FIRE OR ELECTRIC SHOCK

### IMPORTANT SAFETY INSTRUCTIONS - PLEASE DO NOT DISCARD THESE INSTRUCTIONS

**WARNING -** When using electric products, basic precautions should always be followed, including the following:

**This manual contains important instructions for Model CoRe+ that must be followed during installation, operation and maintenance of the unit.**

**Always use a manual screwdriver only; DO NOT use an impact driver for the screws at any times, otherwise, it will void the warranty.**

Carefully read this guide before installing the EVSE.

- 1- CAUTION - To reduce the risk of fire, connect only to a circuit provided with 40 amperes maximum branch circuit overcurrent protection in accordance with the Canadian Electrical Code (CSA C22.1-12) and the National Electrical Code (ANSI/NFPA 70).
- 2- This EVSE was designed to be ground-based, wall-mounted or post-mounted.
- 3- You must make sure that the types of mounting surface of the wall or the post will be strong enough to bear the minimum weight of the EVSE (33 lbs (14.97 kg)), and their anchors must be compatible with the type of mounting surface.
- 4- Verify with local authorities that the location where the EVSE is to be installed is free from underground pipelines or electrical equipment, otherwise you might inflict serious injuries on yourself and others.
- 5- Connect the power supply of the EVSE with caliber 6 to 8 copper conductors rated for usage at a temperature of at least 167 °F (75°C).
- 6- This product must be connected to a grounded, metal, permanent wiring system, or an equipment-grounding conductor must be run with the circuit conductors and connected to the equipment grounding terminal or lead on the product and installed by a certified electrician.
- 7- Communicate with a certified contractor, certified electrician or trained installer to ensure compliance with the local building code, regulation, security standards and weather conditions.
- 8- Any EVSE part alteration will automatically void the warranty.
- 9- Handle parts with care, since they can be sharp-edged. Always use safety glasses and gloves when unpacking and installing.
- 10- Do not install on or over a combustible surface.
- 11- The power supply cables of the EVSE shall be rated FT2 minimum.
- 12- The input cable strain relief, conduit or armed-cable bushings and adapter:
  - A. have to be certified for both Canada and US.
  - B. have to be waterproof (4X enclosure type).
  - C. have to be suitable for the outside diameter of the chosen cable and suitable for mounting into a 1.36 in (34.5 mm) diameter opening (for connection through the bottom cable opening).

## IMPORTANT SAFETY INSTRUCTIONS

This device should be supervised when used around children.

Never insert your finger into the electric vehicle connection.

Never use the EVSE if the flexible power cord or EV cable is frayed, has broken insulation, or any other signs of damage. Never use the EVSE if the enclosure or the EV connector is broken, cracked, open, or shows any other signs of damage. This EVSE was designed to be used with electric vehicles equipped with a SAE-J1772 connector.

This EVSE is to be used to charge vehicles that do not require a ventilated environment during charging.

Make sure to always disconnect the power supply of the EVSE before servicing.

# Dimensions

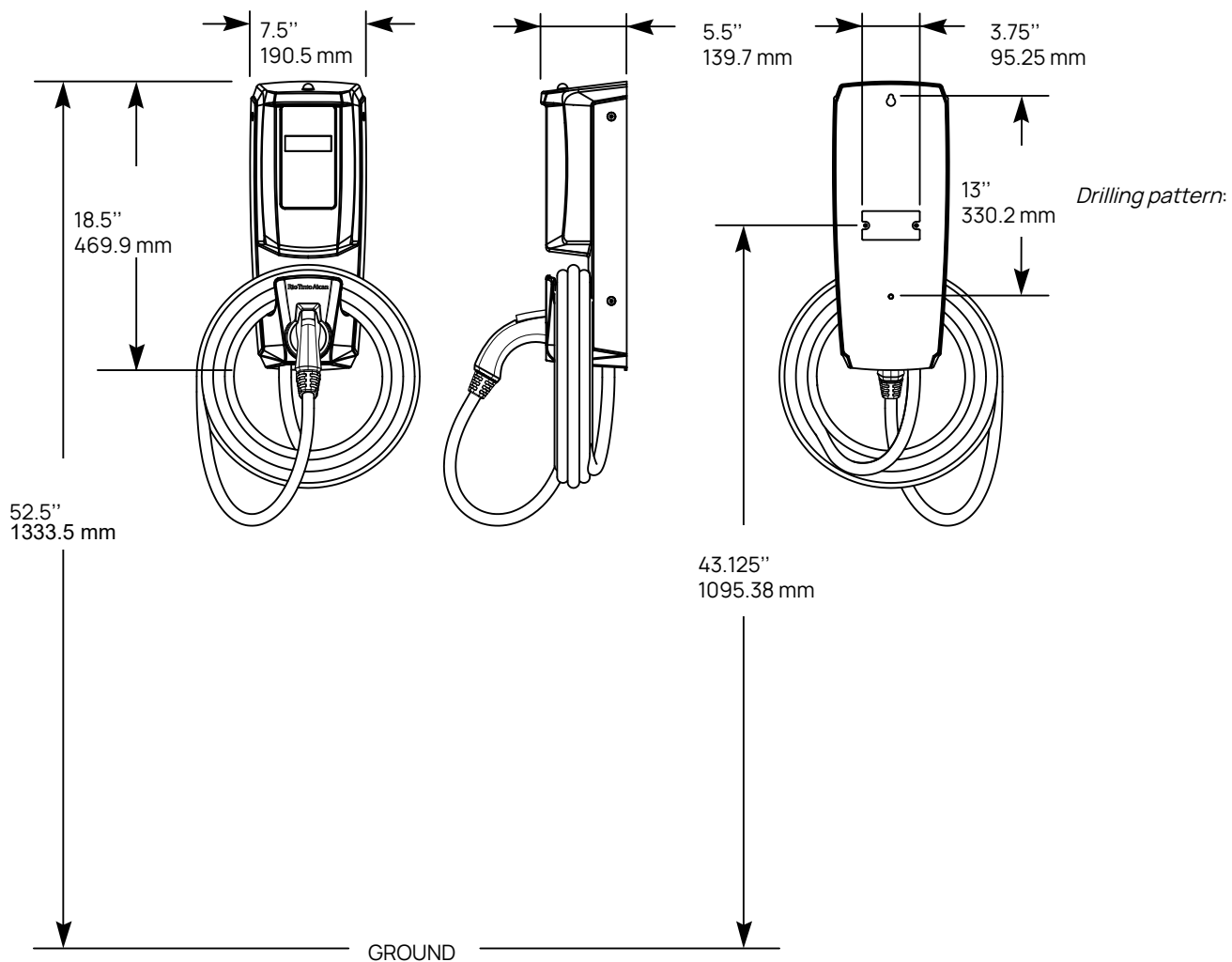

# Wall or Post Mounting

## Power Cable Entry under the Station

- **IMPORTANT:** Never remove the protection plate of the key hole.

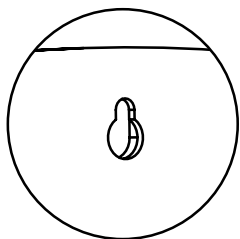

- Attach the head base to the wall or the post with the appropriate type of anchors
- Hang the head base to an anchor (previously fixed to the wall or post) via the keyhole at the top. NEVER REMOVE THE PROTECTION PLATE
- Complete the mounting of the head base by installing an anchor through the bottom hole.

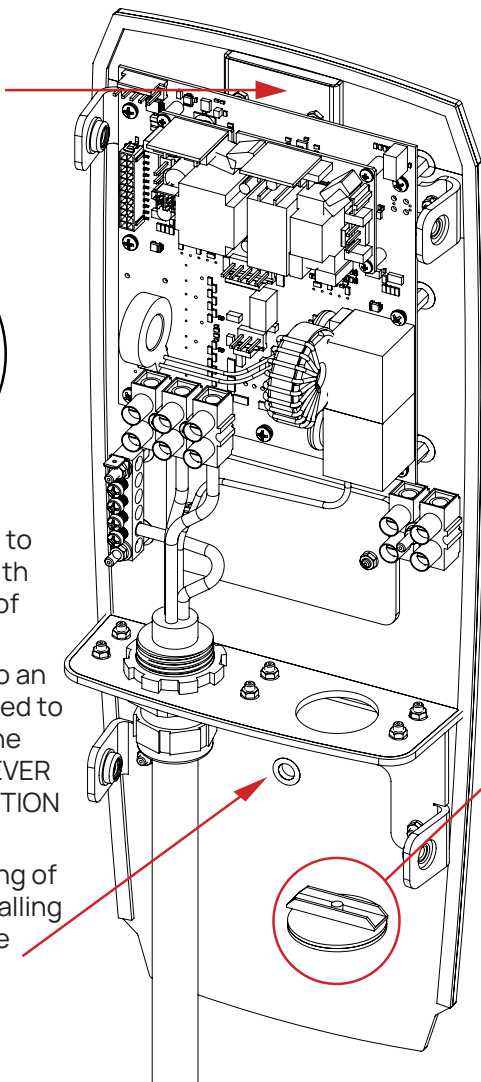

- Avoid installing the EVSE in bad weather conditions.

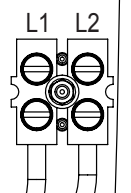
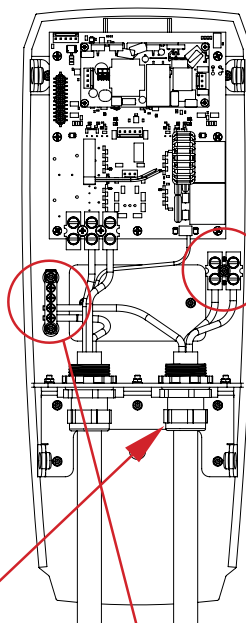

- Connect two power conductors (L1 and L2) and the ground conductor (GND)
- The grounding conductor shall be provided with green or green and yellow insulation.

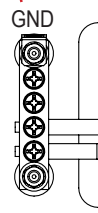

- Remove the hole cover and attach the cable connector to the hole, then insert the power cable. Make sure the conductors are long enough to reach the terminal block.



# Wall or Post Mounting

## Power Cable Entry from the Back

- **IMPORTANT**, never remove the protection plate of the keyhole.

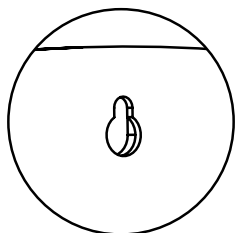

- Attach the head base to the wall or the post with appropriate type of anchors.
- Hang the head base to an anchor (previously fixed to the wall or post) via the keyhole at the top. **NEVER REMOVE THE PROTECTION PLATE**

- Complete the mounting of the head base by installing an anchor through the bottom hole.

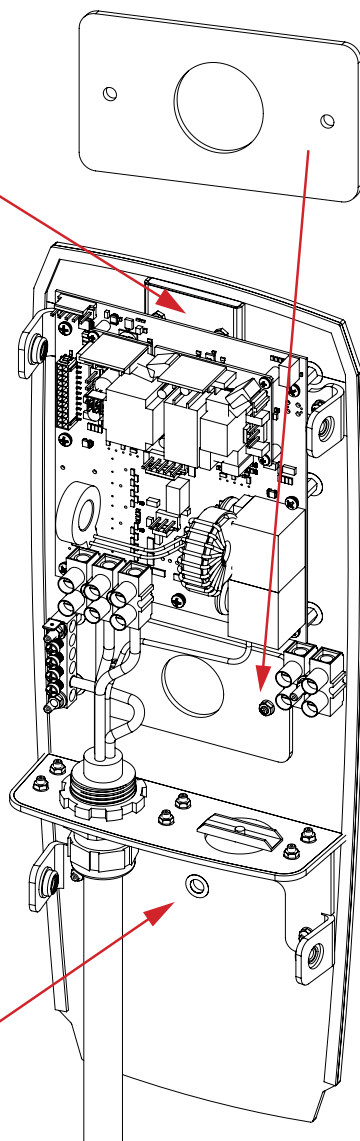

- Remove the plate to avoid the splatter of particles in the equipment.
- Punch a hole of the appropriate diameter to install the cable connector.
- Put the plate back in its place.

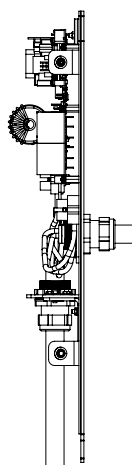

- Install the cable connector to the punched hole, then the cable. Make sure the conductors are long enough to reach the terminal block.

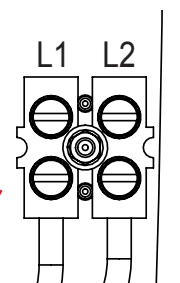

- Connect two power conductors (L1 and L2) and the ground conductor (GND)
- The grounding conductor shall be provided with green or green and yellow insulation.

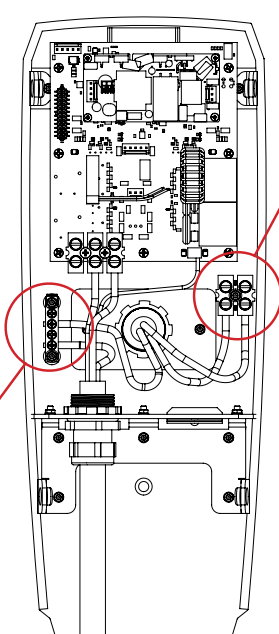
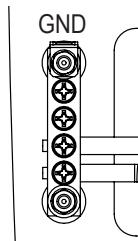

# Wall or Post Mounting With Electrical Box

- **IMPORTANT:** Never remove the protection plate of the keyhole.

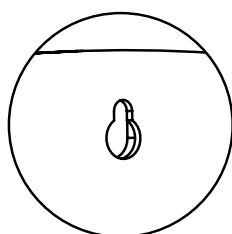

- Attach the head base to the wall or the post with the appropriate type of anchors.
- Hang the head base to an anchor (previously fixed to the wall or post) via the keyhole at the top. **NEVER REMOVE THE PROTECTION PLATE**
- Complete the mounting of the head base by installing an anchor through the bottom hole.

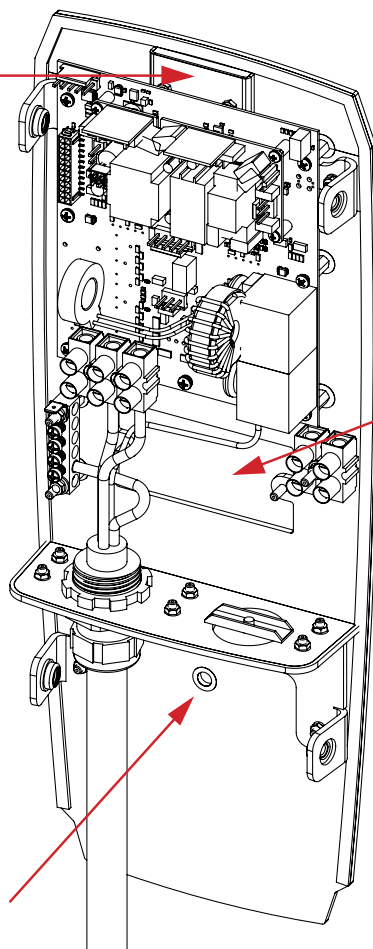

- Remove the backplate.
- Install the head base in order to align the rectangular opening with the box opening in the wall or the post.

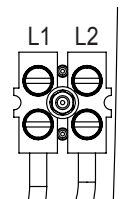
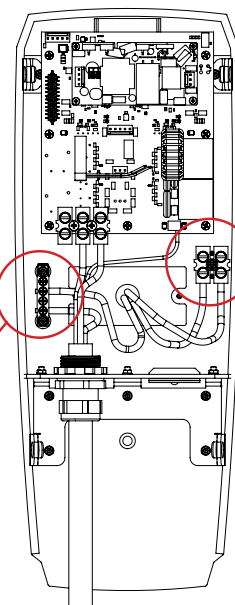
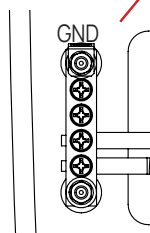

- Connect two power conductors (L1 and L2) and the ground conductor (GND)
- The grounding conductor shall be provided with green or green and yellow insulation.

# Closing the Housing of the Station

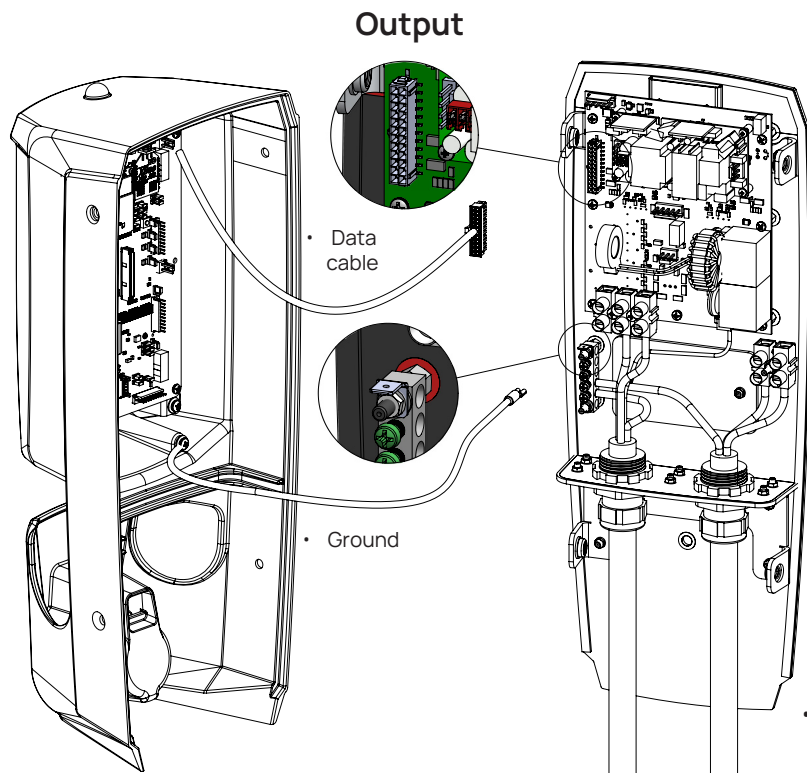

- Connect the cables to their connectors.

- Install the head to the base, making sure that the seals stay in place, then install the four mounting screws.
- Install a o-ring to the upper screw.

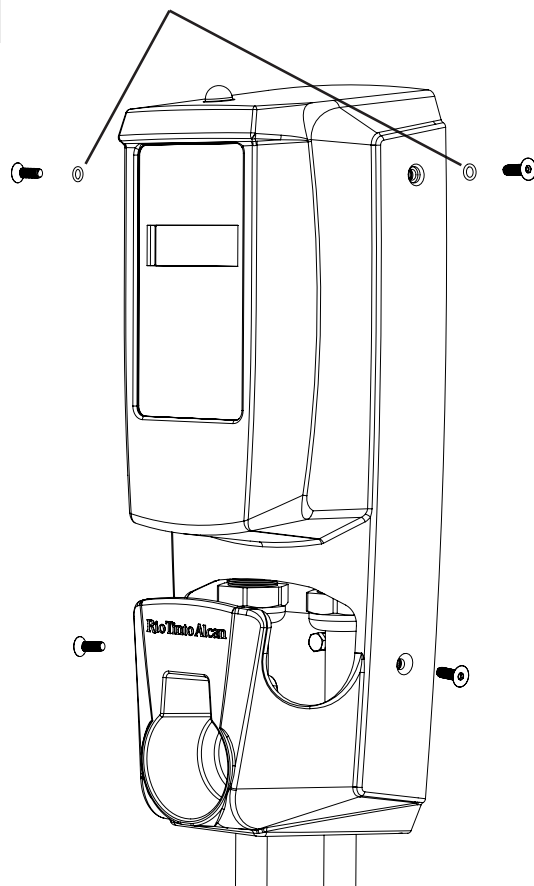

# Preliminary Tests and Commissioning

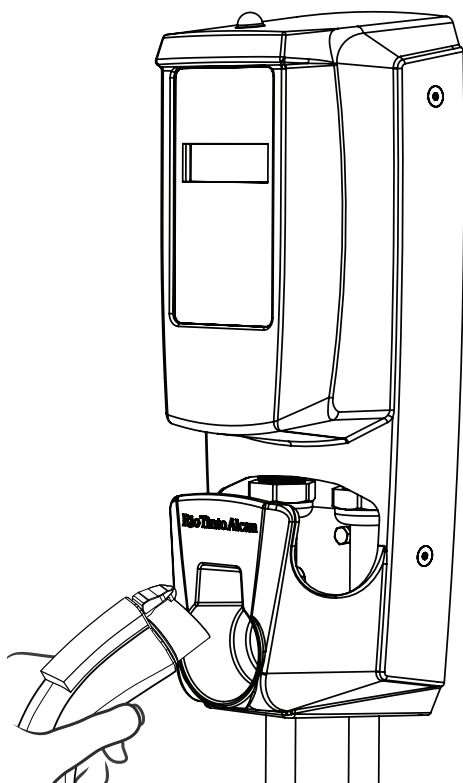
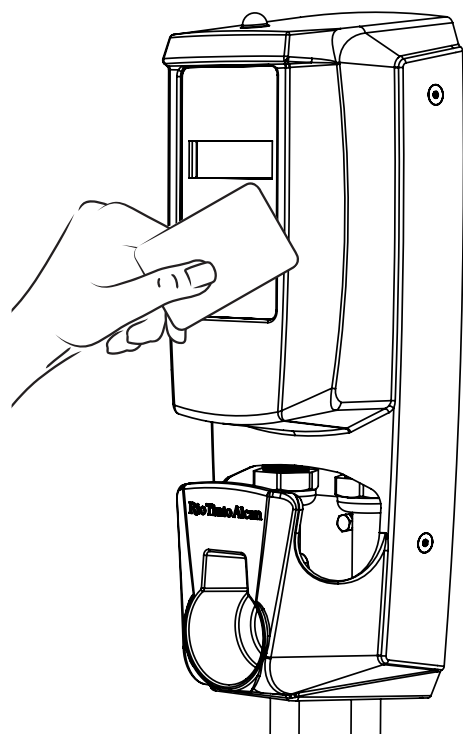

**IMPORTANT:** The commissioning might need to be conducted by an authorized Division of Measurement Standards (DMS) agent if this charging station is intended for use in energy billing mode under commercial application in California. Please call FLO Services for more details.

### Instructions:

- Apply power to the charging station, the following should be observed immediately after power is turned on:
  - 1: The status light is on continuously, its color will be green.
  - 2: The display shows the greeting message.
- Scan the access card provided with the charging head, these results should be observed:
  - 1: Once the reader detects the card, it will emit an audible sound.
  - 2: Immediately after the sound, the access card will be authenticated by the charging station.
  - 3: If the authentication of the card is successful, the automated test of the protection circuit will be performed.
  - 4: Once the test is successfully completed, the overhead status light will start flashing (white).
  - 5: If the connector is inserted into an Electrical Vehicle (EV), it will begin charging, if not, after 1 minute, the station will change to waiting mode.
- Once the preliminary test is successfully passed, the charging station can then be used as a private charging station (using the provided access card(s)), or to be connected to FLO's management system by turning on the communication gateway provided by FLO.

# PowerSharing™

**With the embedded PowerSharing™ capability of the CoRe+PS, up to four charging stations can be connected in parallel to the same branch circuit**

1. The charging stations connected in parallel to a same branch circuit must be the CoRe+PS model (the specific model identification can be found on the unit label).
2. Without a site controller installed or in operation, each CoRe+PS limits its output to 8 A.
3. To enable a dynamic sharing of current, a site controller must be installed and properly configured by FLO.
4. The site controller will then ensure that available maximum current is shared optimally amongst the charging stations (between 8 A and 30 A for each station), while making sure that the maximum circuit capacity (32 A in the case of a circuit protected by a 40 A breaker) is never exceeded.
5. For safety reason, each CoRe+PS charging station will immediately interrupt an ongoing charging session when the connected EV draws more than the amperage limit dictated at any time. To resume charging, the user must restart the usage session process from the beginning.
6. The site controller is provided by FLO as part of central management service.
7. The communication between the site controller and the charging station is through a wireless meshed Zigbee network. Refer to the *Communication Gateway Installation Guide* provided by FLO for more details.
8. The maximum number of charging station sharing the same 40 A circuit (for a total load of 32 A) is 4, although, to keep the charging time reasonable, we recommend not to exceed 3 units per 40 A circuit.

## Typical Installation

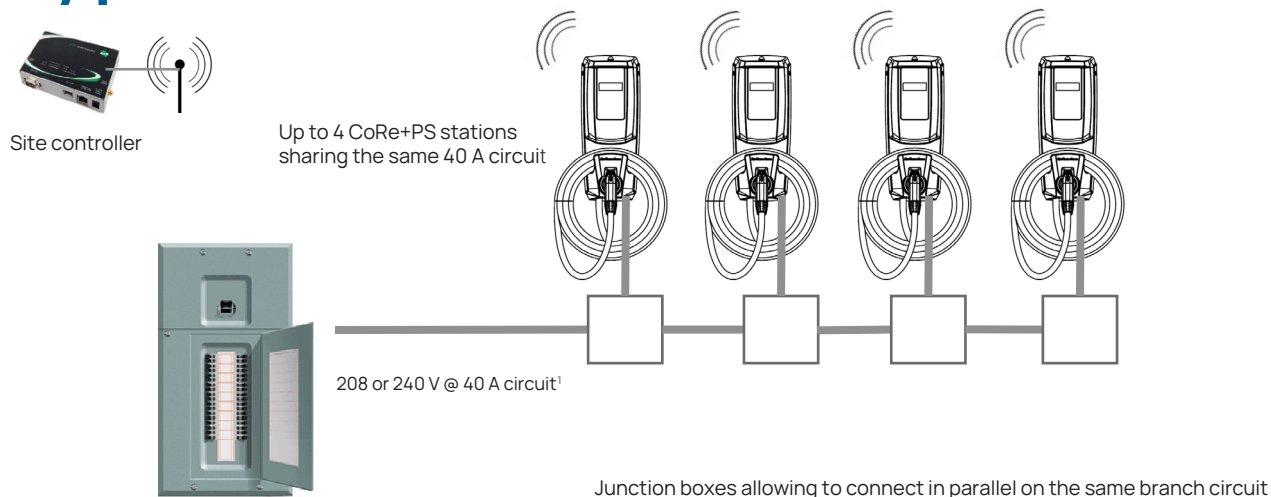

Note 1: The electrical wiring and the associated electrical hardware used to connect in parallel the charging stations shall be compliant to the local regulations in place.

# Installation Guide

## Cascading on a 40 A Circuit

### STEP 1

Mounting bracket preassembly:

The preassembly requires the 40 A cascading kit (AddÉnergie part number C+V1-PWCK-40).

- Install the DIN rail as well as the provided terminal blocks (2 isolated 2-position terminal blocks for the live conductors, and 1 non-isolated terminal block for the grounding conductor) with the provided screws.

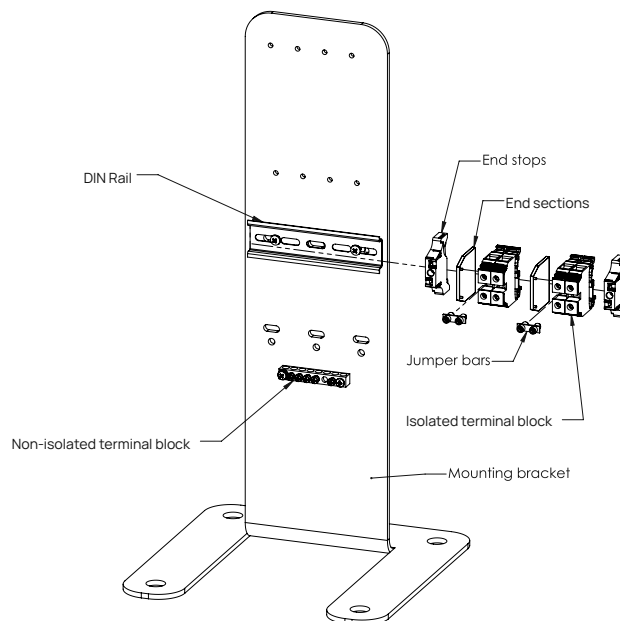

### STEP 2

Mounting bracket installation and power supply cable connection:

- Install the power supply cables coming from the previous charging station and going to the next one, letting 1 foot of cable protrude from the conduit.
- Place the mounting bracket on the concrete base, making sure that the anchor's threaded rods pass through the 4 holes in the base of the bracket.
- Connect the power supply cables to the bottom side of the terminal blocks.

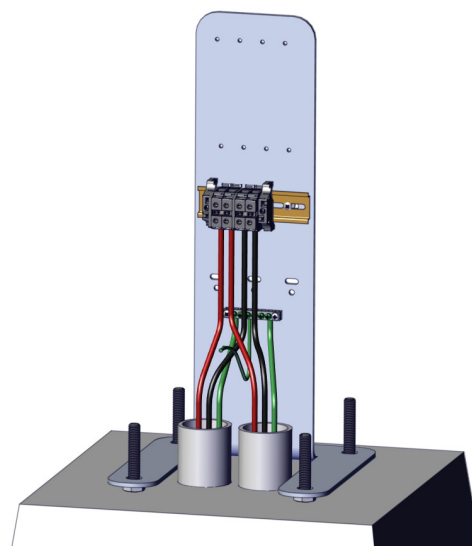

# Installation Guide

## Cascading on a 40 A Circuit

### STEP 3

Pedestal and charging station installation:

- Slide the pedestal over the assembly, making sure that the terminal blocks are facing the access door at the bottom of the pedestal, then tighten the 4 mounting nuts that secure everything to the anchor.
- Unscrew and remove the plates from the pedestal.
- Pass the power supply wires (2 lines and 2 ground connectors) from each rectangular hole at the top of the pedestal down to the terminal blocks.
- Connect the wires feeding the charging stations to their respective breakers and install each charging station on the pedestal, as per the *CoRe+ Installation Guide*.



# Installation Guide Cascading on a 150 A Circuit

## STEP 1:

### Mounting bracket pre-assembly

The pre-assembly requires the 150 A cascading kit (FLO part number C+V1-PWCK-150) and 1-pole or 40 A double pole circuit breaker (FLO part number breaker-40D) depending on the number of charging stations to be mounted on the pedestal.

- Install the 2 provided terminal blocks (1 isolated 3-position terminal block for the live conductors, and 1 non-isolated terminal block for the grounding conductor) and the breakers onto the mounting bracket with the provided screws.
- Connect the power supply cables from the top of the terminal blocks to the breakers, depending on the number of stations to be installed.

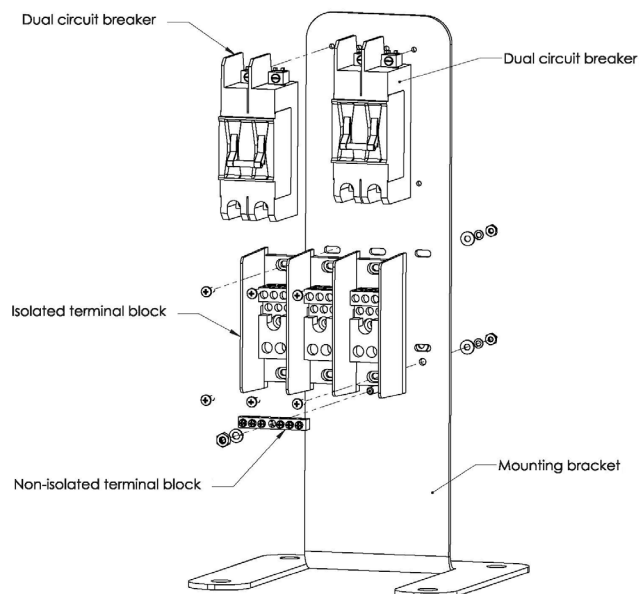

## STEP 2:

### Mounting bracket installation and power supply cable connection:

- Install the power supply cables coming from the previous charging station and the power supply cables going to the next one, letting 1 foot of cable protrude from the conduit.
- Place the mounting bracket on the concrete base, making sure that the anchor's threaded rods pass through the 4 holes in the base of the bracket.
- Connect the power supply cables to the bottom of the terminal blocks.

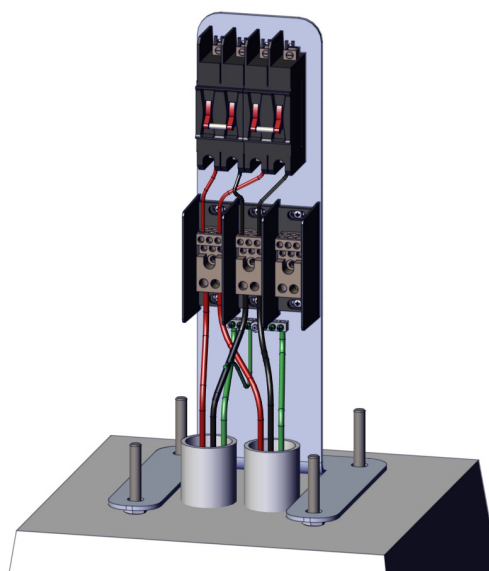



# Installation Guide

## Cascading on a 150 A Circuit

### STEP 3:

Pedestal and charging station installation:

- Slide the pedestal over the assembly, making sure that the terminal blocks are facing the access door at the bottom of the pedestal.
- Tighten the 4 mounting nuts that secure everything to the anchor.
- Unscrew and remove the plates from the top of the pedestal, depending on the number of charging stations to install.
- Pass the power supply wires (2 lines and 2 ground connectors) from each rectangular hole at the top of the pedestal down to the breakers.
- Connect the wires feeding the charging stations to their respective breakers, being careful to keep the phases balanced (in the case of a tri-phase supply) and install each charging station on the pedestal, as per the *CoRe+ Installation Guide*.



## Copyright and Liability

Document Name: FLO\_CoRe+\_Installation Guide\_V.21.0.0\_2023-09-15\_US\_EN  
 Document ID: PRFM0033

FLO CA: © 2023 Services FLO Inc., All rights reserved. FLO, the FLO logo, LEAD THE WAY, and TRACEZ LA VOIE are trademarks of Services FLO Inc. ADDÉNERGIE is a trademark of AddÉnergie Technologies Inc. used under license by Services FLO Inc.

FLO US: © 2023 FLO Services USA Inc., All rights reserved. FLO, the FLO logo, LEAD THE WAY, and TRACEZ LA VOIE are trademarks of Services FLO Inc. used under license by FLO Services USA Inc. ADDÉNERGIE is a trademark of AddÉnergie Technologies Inc. used under license by FLO Services USA Inc.

ALL Documents: This document is provided as a general instruction guide. All pictures shown are for illustration purposes only. Actual stations may vary in size or due to product enhancements, in which case additional steps may be required. AddÉnergie Technologies Inc. and its subsidiaries (“AddÉnergie”) reserve the right to alter this document and any product offerings and specifications at any time without notice and AddÉnergie does not guarantee that that this version of the document is current. It is your responsibility to comply with all applicable laws, including those related to accessibility, zoning, and to exercise due diligence when conducting an installation or using this product. Careless installation or use may result in injury or product damage. To fullest extent permitted by applicable laws, AddÉnergie disclaims any liability for personal injury or property damage resulting from the installation or use of this product.