

KT-WDLED23PS-8B-9CSF-VDIM

8" LED RECESSED WAFER DOWNLIGHT

DESCRIPTION

8" LED Recessed Wafer Downlight | Power Select Technology | Color Select Technology | Remote Driver with Built-in Junction Box

APPLICATION

Ideal for residential, hospitality, retail, office, and other retrofit and new construction applications



PRODUCT FEATURES

- Keystone Power Select and Color Select technologies offer SKU reduction and allow for easy, on-the-job adjustments
- Utilizes a remote driver with built-in junction box and quick disconnect; Eliminates the need for a traditional, multi-piece fixture setup
- CEC Compliant Flicker Rate (CEC JA10 std.)
- Ideal for new construction, remodel, and retrofit applications
- Flat body allows fit for shallow ceilings
- Edge-lit LED technology provides even illumination
- Interchangeable trims available in matte black, brushed nickel, and bronze
- Powered by Keystone 0–10V dimming LED driver; 10–100% dimming
- Ambient operating temperature: –30°C/–22°F to 40°C/104°F
- Suitable for use in wet locations
- Airtight and Type IC-rated
- Power factor: >0.90
- THD: <20%
- LED chip lifetime: L70 >80,000 hrs @ 25°C/77°F ambient fixture temp
- FCC Part 15, Subpart B, Class A

PERFORMANCE SPECIFICATIONS

Catalog Number	Input Voltage	Wattage (Selectable)	CCT (Selectable)*	Lumen Output	Efficacy	CRI	Power Factor	Beam Angle	Lifetime
KT-WDLED23PS-8B-9CSF-VDIM	120–277V	23W	2700K	1,800	78 lm/W	>90	>0.9	110°	50,000 hrs
			3000K	1,850	80 lm/W				
			3500K	1,920	83 lm/W				
			4000K	1,960	85 lm/W				
			5000K	1,925	84 lm/W				
		18W	2700K	1,400	78 lm/W				
			3000K	1,435	80 lm/W				
			3500K	1,475	82 lm/W				
			4000K	1,500	83 lm/W				
			5000K	1,480	82 lm/W				
		14W	2700K	1,100	79 lm/W				
			3000K	1,130	81 lm/W				
			3500K	1,160	83 lm/W				
			4000K	1,185	85 lm/W				
			5000K	1,165	83 lm/W				

*Preset to highest CCT: 5000K
 Color Uniformity: CCT (Correlated Color Temperature) range as per guidelines outlined in ANSI C78.377-2017

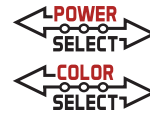

KT-WDLED23PS-8B-9CSF-VDIM

8" LED RECESSED WAFER DOWNLIGHT

PHOTOMETRIC SPECIFICATIONS

POLAR CANDELA DISTRIBUTION

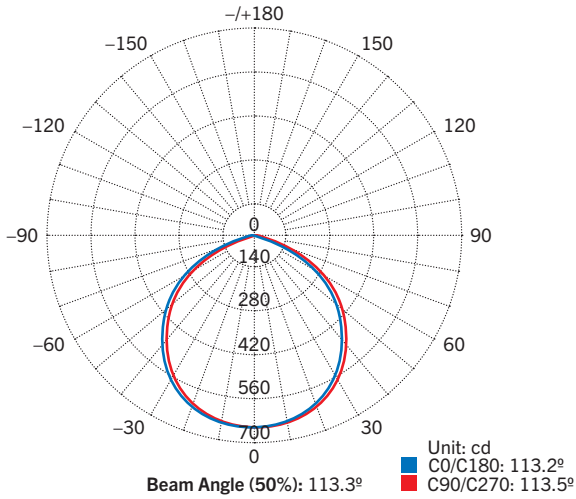

LUX DISTANCE CURVE

Flux Out: 1,407 lm

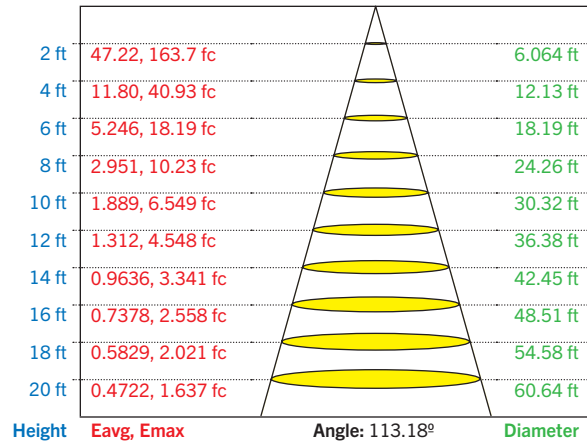

Curves show illuminated area and average illumination when lamp is at various distances.

PHYSICAL SPECIFICATIONS

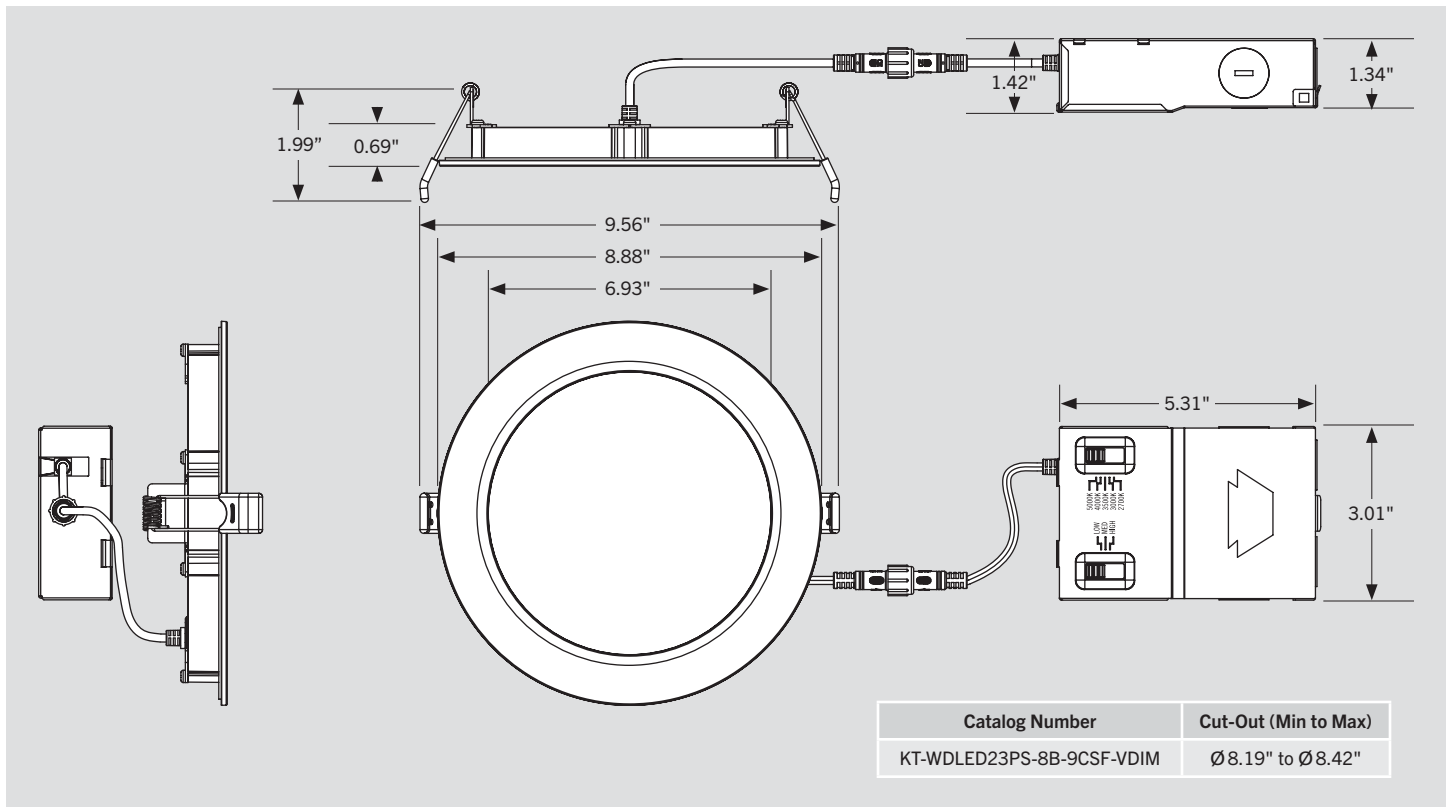

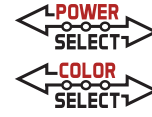

KT-WDLED23PS-8B-9CSF-VDIM

8" LED RECESSED WAFER DOWNLIGHT

POWER SELECT (WATTAGE) AND COLOR SELECT (CCT) ADJUSTMENT

This fixture is equipped with field-adjustable Keystone Power Select and Color Select technology.

1. Ensure power is off to the fixture.
2. Adjust dip switches to desired settings.

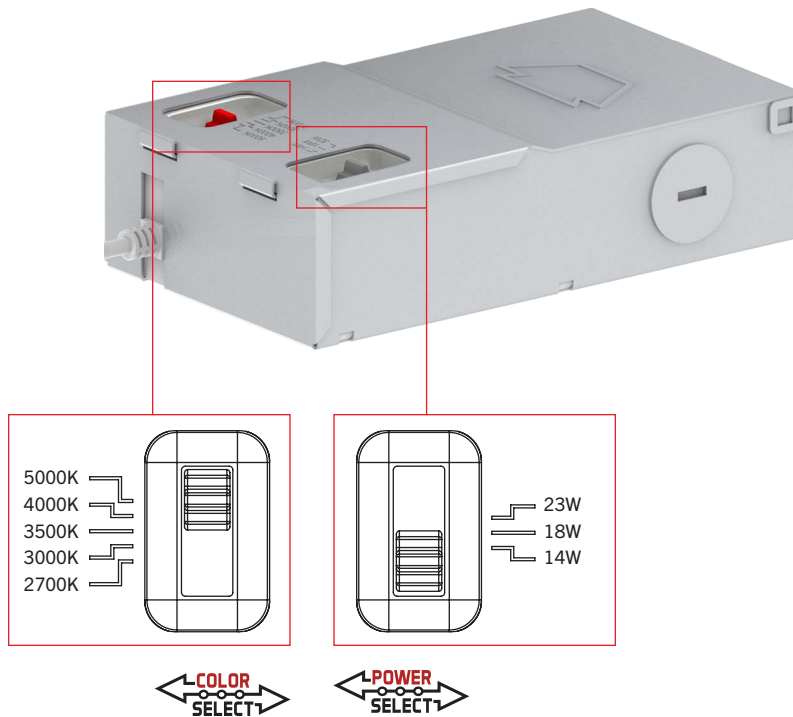

COLOR SELECT ADJUSTMENT SWITCH
 Set dip switch to adjust CCT between 2700K, 3000K, 3500K, 4000K, and 5000K. Fixture comes preset at 5000K.

POWER SELECT ADJUSTMENT SWITCH
 Set dip switch to adjust wattage between 14W, 18W, and 23W. Fixture comes preset at 23W.

WIRING DIAGRAM

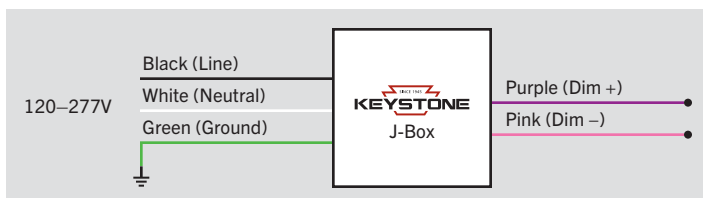

KT-WDLED23PS-8B-9CSF-VDIM

8" LED RECESSED WAFER DOWNLIGHT

INSTALLATION INSTRUCTIONS

RETROFIT INSTALLATION

- 1. Shut off power at the source of the fixture housing into which you are installing fixture.**

Remove existing trim, CFL or incandescent bulb.

Note: Follow all federal and local regulations when disposing of lamps and removed components.

- 2. Measure ceiling opening to ensure that the edge of the luminaire will cover the entire opening and still sit firmly in the ceiling (see *Dimensions* on page 2).**

- 3. Select desired Wattage and CCT using adjustment switches on fixture (see *Power Select (Wattage) and Color Select (CCT) Adjustment* on page 3).**

- 4. Open the driver box and remove the knockout(s) (KO).**

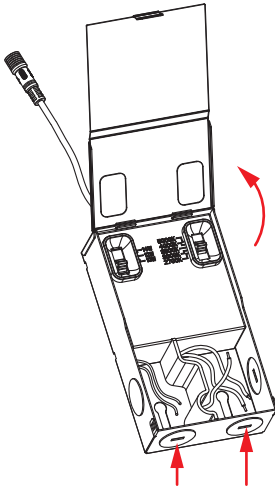

- 5. Insert the electrical supply cable through the KO; use appropriate bushing to prevent wire abrasion. Wire driver box (see *Wiring Diagram* on page 3 and illustration below).***

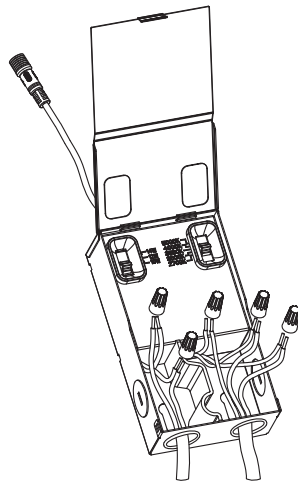

- 6. Place all wiring and connections back into the box and close the cover.**

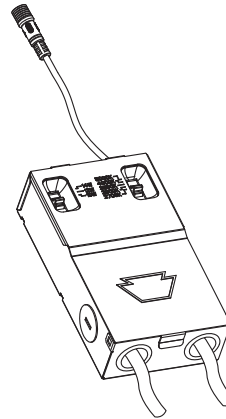

- 7. Insert driver box into ceiling in accordance with local/national codes and connect the male and female connectors. Screw threaded nut over connectors to secure.**

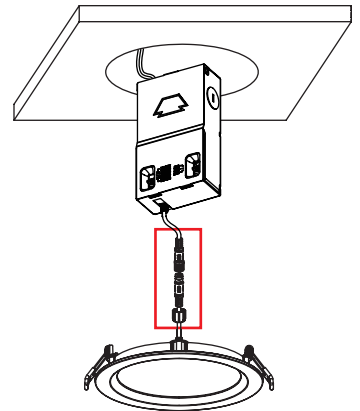

- 8. Lifting both retention tabs upward, push the fixture into the hole until trim sits flush with ceiling.**

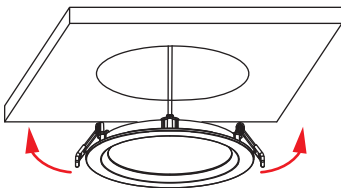

- 9. Restore power when ready.**

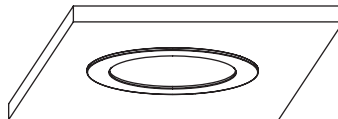

* Keystone offers an optional cable accessory to assist with wiring to existing fixture J-box. See KT-MC-NP-1-18/3, Optional Accessories (sold separately) on page 6.

(Installation Instructions continued on next page)

KT-WDLED23PS-8B-9CSF-VDIM

8" LED RECESSED WAFER DOWNLIGHT

INSTALLATION INSTRUCTIONS (continued)

NEW-CONSTRUCTION INSTALLATION*

1. Shut off power at the source of the fixture housing into which you are installing fixture.
2. Using installation hole template, create ceiling opening to ensure that the edge of the luminaire will cover the entire opening and still sit firmly in the ceiling (see *Dimensions* on page 2).
3. Select desired Wattage and CCT using adjustment switches on fixture (see *Power Select (Wattage) and Color Select (CCT) Adjustment* on page 3).

4. Open the driver box and remove the knockout(s) (KO).

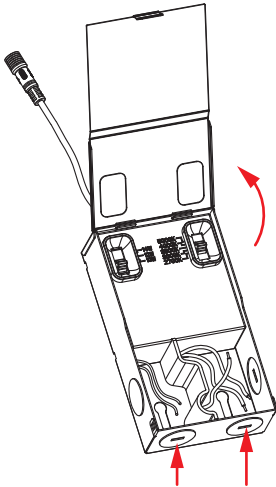

5. Insert the electrical supply cable through the KO; use appropriate bushing to prevent wire abrasion. Wire driver box (see *Wiring Diagram* on page 3 and illustration below).*

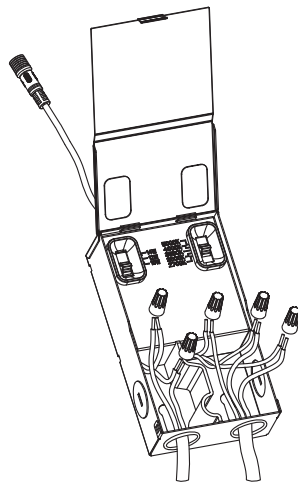

6. Place all wiring and connections back into the box and close the cover.

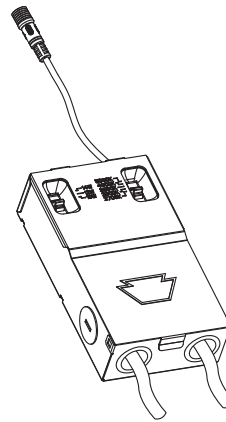

7. Insert driver box into ceiling in accordance with local/national codes and connect the male and female connectors. Screw threaded nut over connectors to secure.

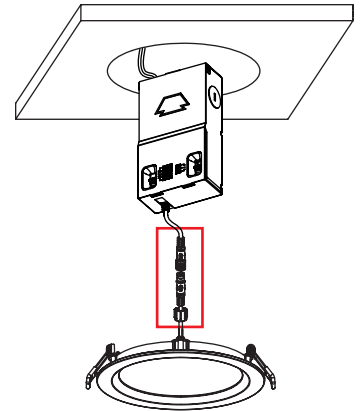

8. Lifting both retention tabs upward, push the fixture into the hole until trim sits flush with ceiling.

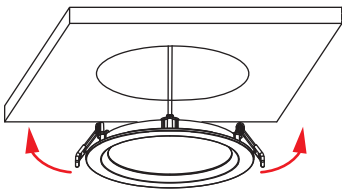

9. Restore power when ready.

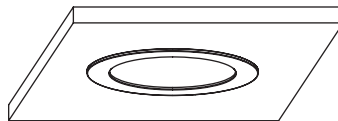

* Keystone offers an optional cable accessory to assist with wiring to existing fixture J-box. See KT-MC-NP-1-18/3, *Optional Accessories* (sold separately) on page 6.